

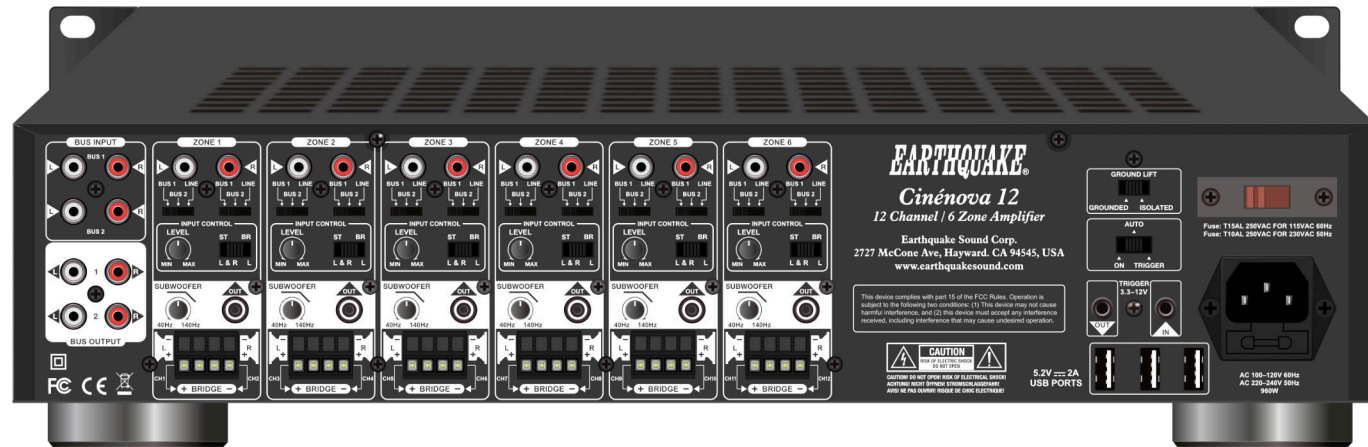

Cinénova 12

12 CHANNEL MULTI-ZONE AMPLIFIER



User Manual

Table of Contents

Warranty Information.....	3
Important Safety Instructions.....	4
Front & Rear Panel Overview.....	5-7
LED Indicators & Clipping Circuitry.....	8
Getting Started.....	9
Wiring Configurations.....	10-15
Specifications & Dimensions.....	16
Troubleshooting.....	17
For Your Records.....	18
Notes.....	19

Cinénova 12

12 CHANNEL, 6 ZONE AMPLIFIER



The Sound That Will Move You

Customer Technical Support
Tel: 1-510-732-1000
tech@earthquakesound.com

Earthquake Sound Corporation
2727 McCone Avenue
Hayward, CA 94545
Tel: 1-510-732-1000

©2024 Earthquake Sound Corporation. All rights reserved.
This document should not be construed as a commitment on the part of Earthquake Sound Corp.
The information is subject to change without notice.
Earthquake Sound Corporation assumes no responsibility for errors that may appear within this document.



WARNING: Earthquake Sound products are capable of generating high sound pressure levels and strongly encourage you to exercise caution during operation. Long term exposures to high levels of sound pressure will cause permanent damage to your hearing. Sound pressure levels exceeding 85dB can be dangerous with constant exposure. Set your audio system to a comfortable loudness level. Earthquake Sound Corp. does not assume liability for damages resulting from the direct use of Earthquake Sound audio product(s) and urges users to play volume at moderate levels.

Five (5) Year Limited Warranty

Earthquake warrants the original purchaser that all Factory Sealed New Audio Products to be free from defects in material and workmanship under normal and proper use for a period of **five (5) years** from the date of purchase (as shown on the original sales receipt with serial number affixed/written on it). The five (5) year warranty period is valid only if an authorized Earthquake dealer properly installs the product and the warranty registration card is properly filled out and sent to Earthquake Sound Corporation. If a non-authorized party installs the product, a ninety (90) day warranty period will be applied.

(A) Five (5) years limited warranty plan coverage guidelines:

- **First year:** Earthquake pays for labor, parts, and ground freight (only in US mainland, not including Alaska and Hawaii) (shipping to us is not covered).
- **Second, third, fourth & fifth year:** Earthquake pays labor only. Customer must pay for parts and freight both ways.

(B) Warning:

Products (sent for repair) that are tested by Earthquake technicians and deemed to have no problem(s) will not be covered by the five (5) year limited warranty. Customer will be charged a minimum of one (1) hour of labor (at the ongoing rates) plus shipping charges back to customer.

Each product sent for repair **must be packaged in its original packaging.**

Otherwise, there will be repackaging charge in addition to labor, parts and shipping charges.

(C) Earthquake will repair or replace - at our option - all defective products/parts subject to the following provisions:

- Defective products/parts have not been altered or repaired by other than an Earthquake factory-approved technician.
- Products/parts are not subjected to negligence, misuse, improper use or accident, damaged by improper line voltage, used with incompatible products or have its serial number or any part of it altered, defaced or removed, or have been used in any way that is contrary to Earthquake's written instructions.

(D) Warranty Limitations:

Warranty does not cover products that have been modified or abused, including but not limited to the following:

- Damages to cabinet/casing finish due to misuse, abuse or improper use of cleaning materials/methods.
- Fading and or deterioration of speaker components & finish due to improper exposure to elements.
- Bent amplifier casing, damaged finish on the casing due to abuse, misuse or improper use of cleaning material.

- Burnt tracers on PCB.
- Product/part damaged due to poor packaging or abusive shipping conditions.
- Subsequent damage to other products.

A warranty claim will not be valid if the warranty registration card is not properly filled & returned to Earthquake with a copy of the sales invoice.

(E) Service Request:

To receive product service, contact Earthquake service department at (510) 732-1000 and request an RMA number (Return Material Authorization). Items shipped without a valid RMA number will be refused. Make sure you provide us with your complete/correct shipping address, a valid phone number, and a brief description of the problem you are experiencing with the product. In most cases, our technicians might be able to resolve the problem over the phone; thus, eliminating the need to ship the product.

(F) Shipping Instructions:

Product(s) must be packaged in its original protective box(es) to minimize transport damage. Shipper claims regarding items damaged in transit must be presented to carrier. Earthquake Sound Corporation reserves the right to refuse improperly packed product. Original sales receipt must accompany product returned for service. We encourage you to include with the package a written description of the problem.

Ship product to: Earthquake Sound Corp. 2727 McCone Avenue, Hayward, CA 94545. Phone: (510) 732-1000. You are responsible for the cost of shipping the product to Earthquake Sound Corporation.

(G) Disputes Resolution:

All disputes - between clients and Earthquake Sound Corporation - resulting from the five (5) years limited warranty policy must be resolved according to the laws & regulations of the county of Alameda -California.

Product Registration

This Cinénova 12 channel power amplifier can be registered by returning the **Product Registration** card attached to this manual. Please also retain the sales receipt which represents the proof of purchase and helps expedite warranty issues.

Important Safety Instructions

- Read these instructions in their entirety.
- Store this manual and packaging in a safe place.
- Heed all warnings.
- Follow instructions (do not take short cuts).
- Do not use this apparatus near water.
- Clean only with a dry cloth.
- Do not block any ventilation openings. Install in accordance with the manufacturers instructions.
- Do not install near any heat sources such as radiators, heat registers, stoves, or other apparatuses that produce heat.
- Do not defeat the safety purpose of the polarized or grounding-type plug. A polarized plug has two blades with one wider than the other. A grounding-type plug has two blades and a third grounding prong. The wide blade or the third prong is provided for your safety. If the provided plug does not fit into your outlet, consult an electrician for replacement of the obsolete outlet.
- Protect the power cord from being walked on or pinched, particularly at plugs, convenience receptacles, and the point where they exit from the apparatus.
- Only use attachments & accessories specified by the manufacturer.
- Use only with a cart, stand or table that can support the product weight, NOT RACK MOUNTABLE. Use caution when moving or positioning your rack or cart so that it will not tip over, which may cause serious bodily injury to you or damage to your products.
- Unplug this apparatus during a lightning storm or when unused for long period of time.
- Refer all servicing to qualified service personnel. Servicing is required when the apparatus has been damaged in any way such as: power-supply cord or plug is damaged, liquid has been spilled or objects have fallen into the apparatus, the apparatus has been exposed to rain or moisture, does not operate normally, or has been dropped.
- To reduce the risk of fire or electric shock, do not expose this apparatus to rain or moisture.

The following symbols are used in this document:



Appears on the component to indicate the presence of uninsulated, dangerous voltage inside the enclosure – voltage that may be sufficient to constitute a risk of shock.

CAUTION

Calls attention to a procedure, practice, condition or the like that, if not correctly performed or adhered to, could result in injury or death.

WARNING

Calls attention to a procedure, practice, condition or the like that, if not correctly performed or adhered to, could result in damage to or destruction of part or all of the product.

Note:

Calls attention to information that is essential to highlight.

Introduction

Engineered by audiophiles for audiophiles, the Earthquake Cinénova 12 amplifier is a game-changing product that boasts twelve high-performance power channels and six subwoofer RCA outputs, complete with a six built-in variable crossovers. Its superior sound quality and efficiency make it a must-have for audiophiles, as it can easily be added to any room thanks to its flexibility and the addition of a passive subwoofer/s. The Cinénova 12 has advanced features that can be customized to fit most audio systems.

The sleek and modern design of the Cinénova 12 amplifier makes it an attractive addition to any home theater setup. Its user-friendly interface ensures seamless navigation and control. It also features advanced protection circuitry to prevent damage to the unit and the connected speakers. With music and movie playback versatility, the Cinénova 12 is an outstanding investment for any home or commercial audio installations. The Cinénova 12 is a top-of-the-line product that delivers exceptional sound quality and efficiency.

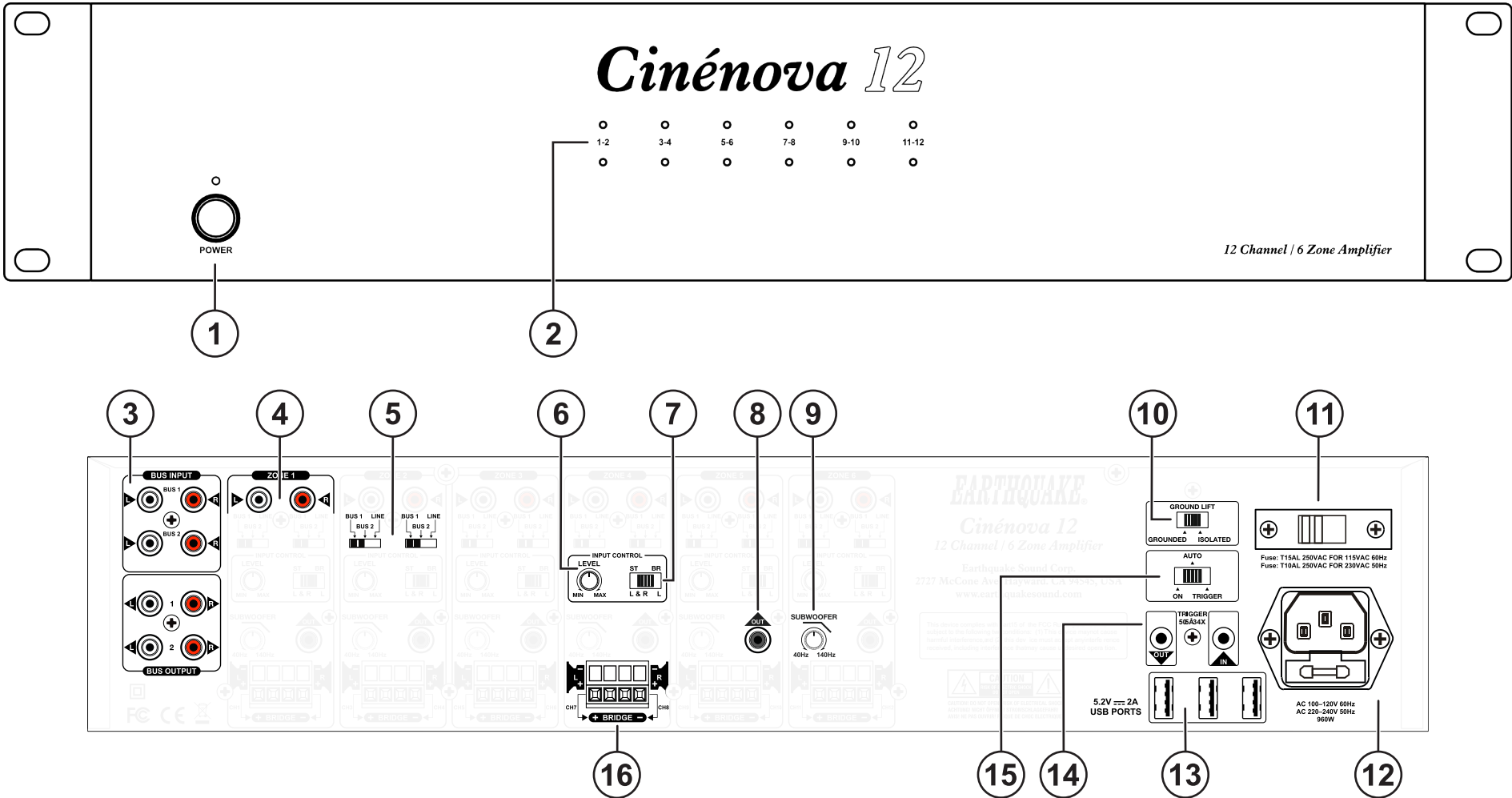

Cinénova 12 Front & Rear Overview

1. Master Power Button & LED Indicator

The power button switch is located on the amplifier's front panel and is used to turn the device on or off. When pushed to the "On" position, the amplifier enters standby mode, and the LED indicator turns red. The Auto/On/Trigger selector, located at the rear, can be in either On, Auto, or Trigger mode. Once the LED indicator turns blue, the amplifier is fully active. Note that the master power button can turn off the amplifier no matter the position of the remote turn-on switch. When the power button LED is not illuminated, the amplifier is completely off and not receiving power.

2. Zone Status LED Indicators

Each pair of channels or zones has a red and blue LED to indicate its operational status. These indicators provide quick and easy troubleshooting of the amplifier. In the event that the circuitry detects that a channel/s must be shut down due to excessive heat or low impedance (a short), only the affected channel/s will be turned off, forcing the zone LED to turn red. The remaining zones will continue to operate and maintain a blue LED status. Once the status has been corrected for the given zone/s, the status LED will return to blue. Note that the unit is in standby mode when the power LED is red, and the zone status LEDs are not illuminated or off.

3. BUS Line RCA Inputs & Outputs

The Cinénova 12 amplifier comes with a pair of BUS line inputs that can receive audio signals from standard line-level audio sources and transmit them to any or all amplifier channels. This amplifier is also equipped with a pair of BUS line outputs for sending signal to additional amplifiers if needed. It is recommended that high-quality RCA cables with low impedance, shielding, and high-quality connectors be used for optimal performance. Please note that running "MONO" to all channels of the amplifier can be accomplished by utilizing the BUS INPUTS/OUTPUTS in conjunction. More information of outputting a Mono signal is discussed further in this manual.

4. Individual Line RCA Inputs

All twelve channels have their own dedicated line RCA inputs that allow for the connection of audio sources in addition to the common BUS line inputs. This is useful when using this amplifier with an audio matrix switcher.

5. Input Selector

Each channel can receive a source signal from multiple inputs. The primary inputs are BUS 1, BUS 2, and LINE IN. Use the input selection switch for the respective channel to make the selection. Pick the desired input source and

position the switch to BUS 1 (for the source connected to the BUS 1 input), BUS 2 (for the source connected to the BUS 2 input), or LINE IN (for the source connected to the channel's LINE IN).

6. Channel Level/Gain Control

Each channel can receive a source signal from multiple inputs. The primary inputs are BUS 1, BUS 2, and LINE IN. Use the input selection switch for the respective channel to make the selection. Pick the desired input source and position the switch to BUS 1 (for the source connected to the BUS 1 input), BUS 2 (for the source connected to the BUS 2 input), or LINE IN (for the source connected to the channel's LINE IN).

7. Stereo & Bridging Selector Switch

This selector lets you combine two channels on a given zone to increase the power output. This feature is convenient when extra power is required for a specific zone. Note that the minimum impedance required for bridged channels is 8-Ohms, and proper speaker wiring must be followed when bridging channels. The left channel will control input selection and volume settings for bridged channels. "BR" indicates bridged mode, while "ST" represents stereo mode. Ensure the amplifier is turned off before switching between modes.

8. Subwoofer RCA Outputs

Each zone has its own subwoofer RCA output that can be used to either connect an active/powered subwoofer or subwoofer amplifier to the Cinénova 12 or connect a single RCA cable from the SUB OUT for that zone to the next zone's RCA LINE IN Left channel.

9. Crossover For Subwoofer Outputs

Each zone has its own independent crossover knob with variable LPF (Low Pass Filter) that is adjustable from 40Hz-140Hz. The crossover knobs allows for frequencies below the chosen cut off frequency to pass through, preventing it from interfering with other speakers or producing unwanted frequencies. This ensures that the subwoofer/s blend seamlessly with the rest of your audio system.

10. Ground Lift Selector Switch

This switch addresses unwanted ground-related noise caused by ground loops in audio cables. If a ground loop occurs, adjust the switch to reduce or eliminate any audible hum or buzz noise from your sound system.

Cinénova 12 Front & Rear Overview Cont.

11. Switchable 110/220V Input Voltage

The Cinénova 12 amplifier works in both 110V and 220V environments. **Before powering on the amplifier, ensure this switch is in the correct position.** For 220V operation, adjust the voltage selector switch to the 220V position. Remember that when operating the amplifier at 220V, the internal fuse found in the IEC socket must also be changed.

12. IEC Power Connector

The Cinénova 12 amplifier has a fused IEC power inlet, allowing the flexibility to change the power cable for different countries. The main fuse holder is located just beneath the IEC inlet and can be accessed by prying off the cover with a flathead screwdriver. Avoid plugging the amplifier's power cable into a switched outlet. To have the amplifier turn on when the AV receiver is powered up, use one of the power modes, such as Trigger or Auto.

13. 5.2V/2A USB Ports

The three 5.2V/2A USB ports integrated into the amplifier are designed to supply power to other external devices such as wireless Bluetooth adapters. Please note that these ports solely serve as power sources and do not facilitate data transfer or media functions.

14. Trigger Input & Output

The amplifier's trigger input is a convenient way to connect it to an automated audio system. The 3.5mm mini plug jack accepts a 3.3–12V AC/DC output from another device or a separate power supply. The trigger input activates the amplifier, turning it from standby to ON mode. If using the Cinénova 12 with an AV receiver that lacks a trigger output, the voltage can come from a 12V wall wart (3.5mm tip-positive connector) plugged into the receiver's switched outlet and the trigger input. Moreover, the amplifier's output trigger voltage (12V DC @ 50mA max.) can turn other audio system devices on and off. Note that the amplifier has a delay of approximately 15 minutes before it goes into standby when using the "Auto" turn-on mode. Additionally, the voltage will drop to zero when the amplifier turns off, entering standby mode.

15. On/Auto/Trigger Selector Switch

On Mode

The zone LEDs will remain deactivated until an audio signal is detected in the BUS or LINE IN inputs. Upon detection of an audio signal, the amplifier will power on immediately, and the corresponding zone LEDs will light up in blue to signify which zone/s are active. If no audio signal is present for approximately 20 minutes, the zones will enter a low power state and the zone LEDs will turn off. The LEDs will remain off until an audio source is detected in each corresponding zone input.

Auto Mode

The Cinénova 12 amplifier features an auto mode that detects audio signals and switches on automatically. If there has been no audio signal for around 20 minutes, the amplifier will enter standby mode. While in sleep/standby mode, there will be a 10 to 15 second delay before the amplifier powers back on and audio playback resumes.

Trigger Mode

The Cinénova 12 can be turned on and off by utilizing the 12V trigger input and/or output. Please note that after power is applied to the trigger, there will be a few seconds' delay before an audio signal is played. For everyday use, it is best to leave the amplifier in the "ON" position. Please note that a 3.5mm MONO male to male cable does not come with the Cinénova 12 amplifier and that the use of a 3.5mm STEREO will not work for the 12V Trigger feature.

16. Speaker Output Terminals

The Cinénova 12's speaker connections employ high-quality Phoenix-style connectors. Using 14-18 gauge stranded two-conductor wire for your loudspeakers is recommended. Ensure at least a 2-inch separation between each wire, and strip away roughly a quarter-inch of insulation from each wire. Correctly connect the corresponding speaker wire for each screw terminal, observing proper polarity. Also, when bridging channels, ensure proper speaker wiring protocol is maintained.

LED Indicators and Anti-Clipping Circuitry: What You Need to Know

Front Panel LED Reference Chart

	LED COLOR	DESCRIPTION
POWER	BLUE	Amplifier is on
	RED	Amplifier is in standby, no signal
	OFF	Amplifier is off

CHANNEL	LED COLOR	DESCRIPTION
	BLUE	Zone is active
	RED	Zone fault
	OFF	No signal

CLIP	LED COLOR	DESCRIPTION
	RED FLASHING	Source is set too high
	OFF	Source is set correctly

Note: If a channel LED is RED, you have a fault and need to fix the issue. Once settled, the indicator should turn back to BLUE if the zone is being used or OFF if the zone is not being used. A fault is typically the positive and negative speaker wires touching.

Note: If one of the clip LED indicators is flashing, then that zone is being clipped. Anti-clipping circuitry will automatically reduce the output level going to the speaker from the amplifier when it senses the volume is too loud. The RED clipping LED will continue to flash until you lower the source or the input gain control for that zone.

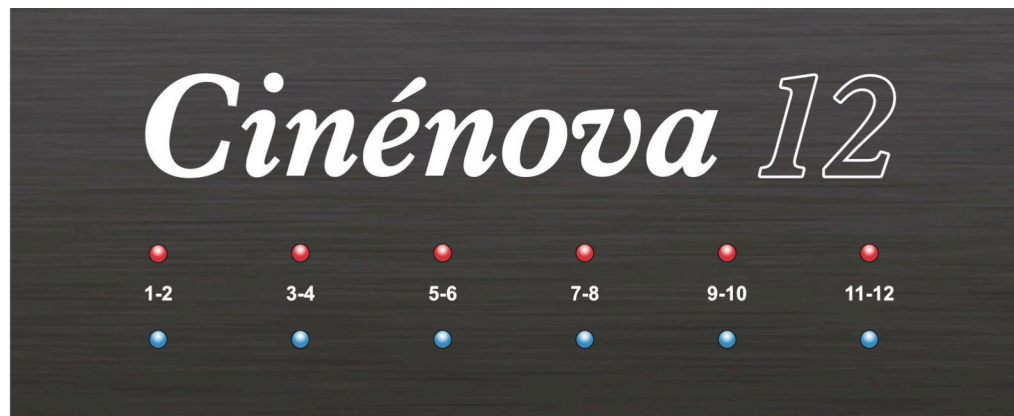
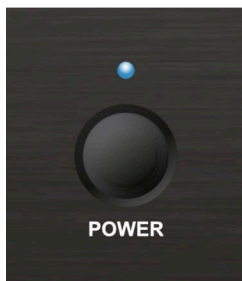

Getting Started With The Cinénova 12

Before you begin, confirm the voltage setting of the amplifier. It must match the voltage in your home. The amp is set by factory to either 110V or 220V. Check above the circuit breaker for this information.

1) INPUT SELECTION

Position the input selector for each channel to either BUS 1, BUS 2, or LINE. This tells the amp which input type will be used for the given zone.

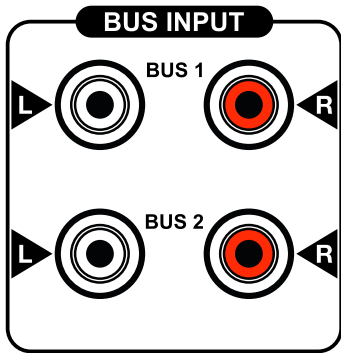
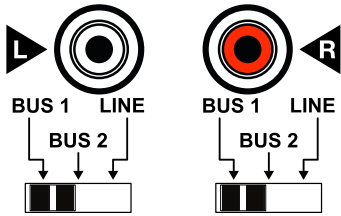

2) SPEAKER CONNECTIONS

A pair of speaker terminals are provided for each channel. These terminals accept bare wire only. Strip approximately a quarter inch of insulation from the end of each wire and carefully twist the strands of each conductor together. Use 14–18 gauge stranded two conductor wire for each loudspeaker and ensure the polarity is correct when wiring the channel in STEREO or BRIDGED configuration. Adjust the ST & BR selector to the correct position. Do this for all channels being used.

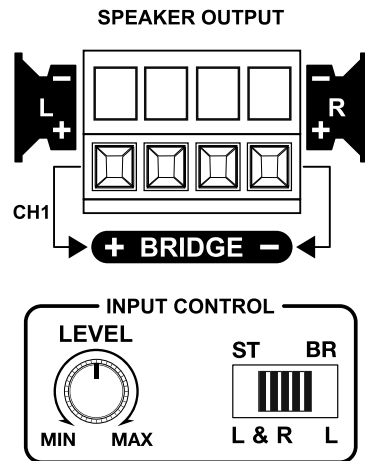

3) 12V TRIGGER INPUT

If you plan to use the Remote Turn-On feature of this amplifier to turn it on from an external source such as a compatible AV receiver, you will need a 3.5mm mono male to male cable. Do not use a 3.5mm stereo cable. Run the cable from your external source to the 3.3–12V TRIGGER IN and adjust the switch above to the TRIGGER position. When powering on your AV receiver or processor, the amplifier will turn on with it. Additionally, you can connect another 3.5mm mono cable from the TRIGGER OUT to another device or amplifier if needed.

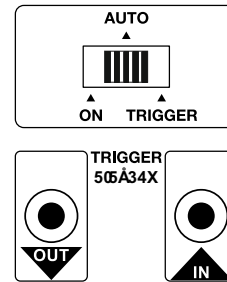

4) INPUT AC AND POWER CORD

The Cinénova 12 can operate in 110V and 220V environments. Before powering the amplifier on, make sure that the Input AC Selector is in the correct position and that you also have the correct fuse installed. Plug the AC power cord into the amplifier first and then into the wall outlet. Make sure it is firmly connected.

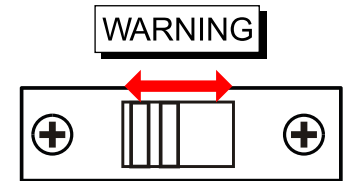

Fuse: T15AL 250VAC FOR 115VAC 60Hz
Fuse: T10AL 250VAC FOR 230VAC 50Hz

CAUTION

The fuse holder is located directly under the power socket. It contains one extra 15 ampere, 250V fuse. When accessing the fuse holder, first make sure your Cinénova 12 is turned off and unplugged from both the wall outlet and the amplifier's power socket. Place a flat head screwdriver just above the groove on the top of the fuse holder to pry it off.

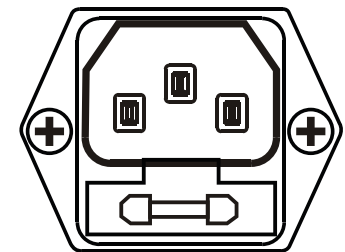

AC 100–120V 60Hz
AC 220–240V 50Hz
960W

General 6 Zone Wiring Sample

Ensure that the STEREO / BRIDGE switch is in the correct position prior to operation. This must be done for all channels that are being driven.

NOTE:
 Stereo Wiring: 21V AC (4-Ohm Minimum - 110W RMS / 200W MAX)
 Mono Wiring: 42V AC (8-Ohm minimum - 220W RMS / 400W MAX)

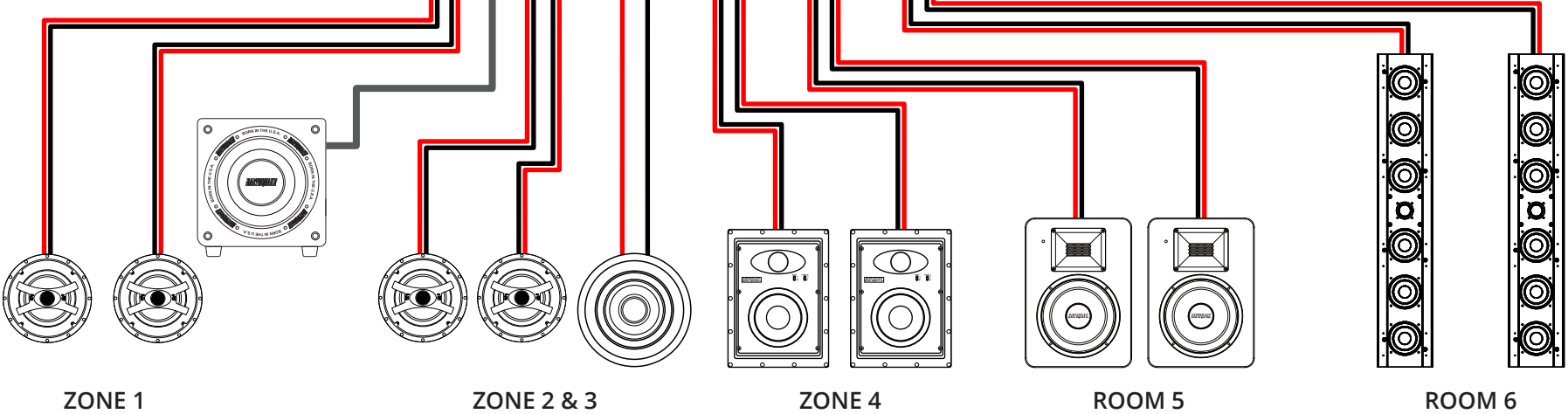
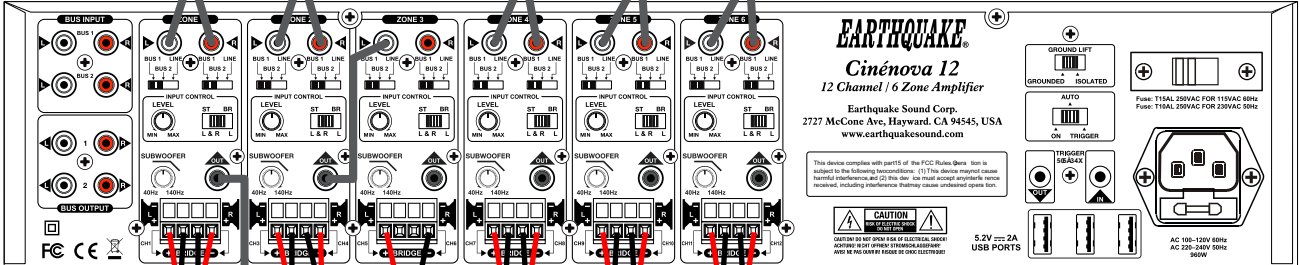
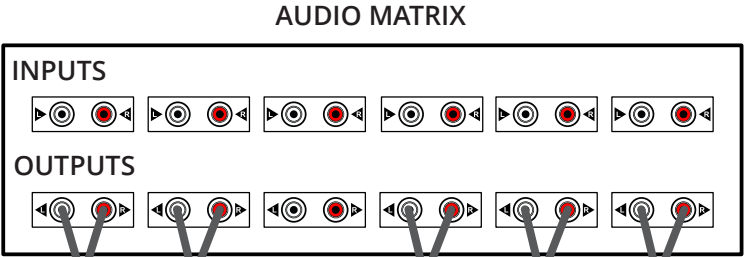
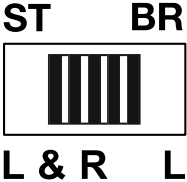

Wiring Configurations

Standard 2-Channel Stereo Wiring

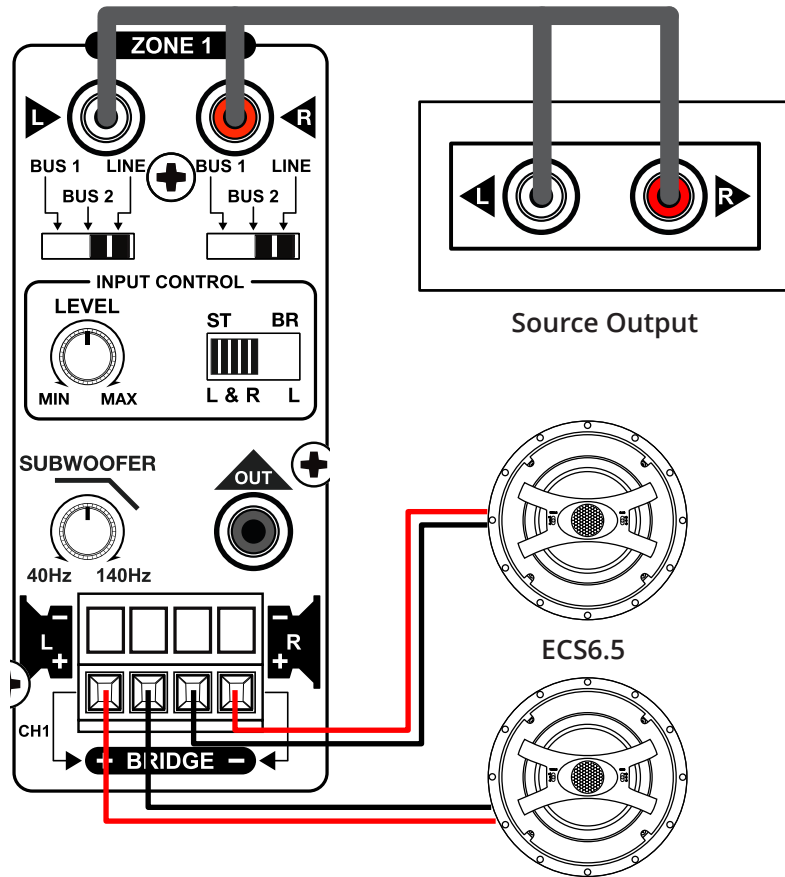

1. Attach your source to the RCA LINE IN or BUS INPUT
2. Set the input switch to the appropriate source
3. Set the ST/BR switch to ST (Stereo)
4. Attach your two speakers to the phoenix connector, left & right channel.

Powered Subwoofer Wiring

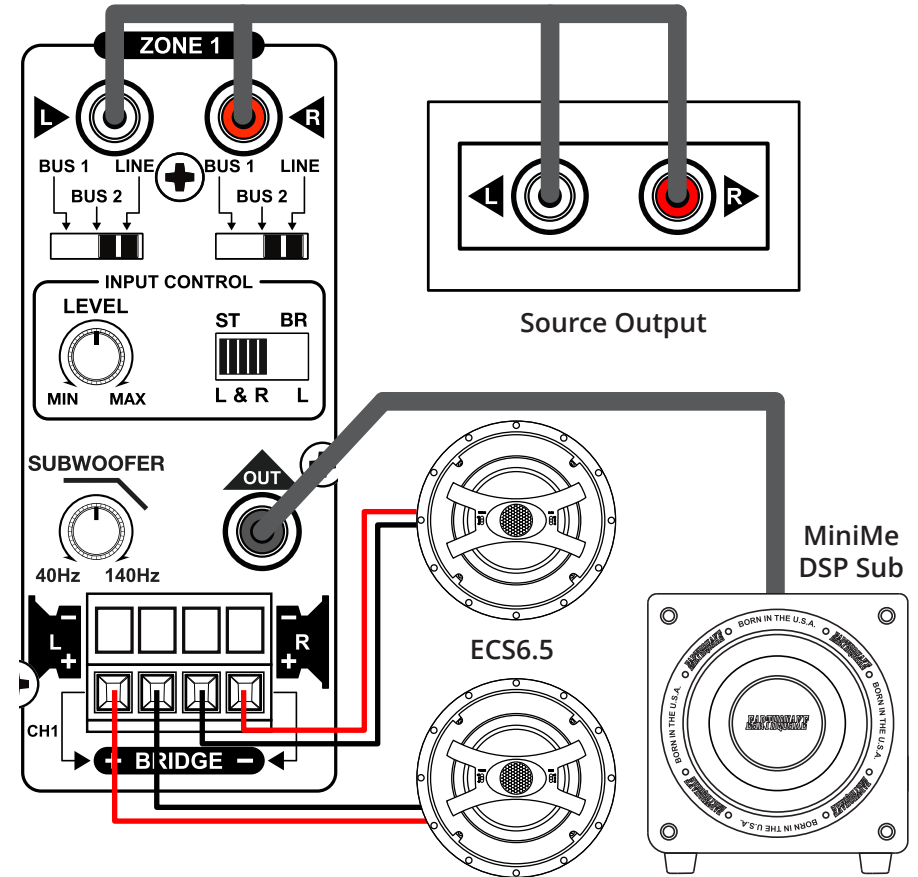

1. Attach your source to the RCA LINE IN or BUS INPUT
2. Set the input switch to the appropriate source
3. Set the ST/BR switch to ST (Stereo)
4. Attach a single RCA wire from the SUB OUT of that zone to a powered subwoofer or subwoofer amplifier.
5. Turn the subwoofer crossover knob clockwise to the 140Hz position and use the crossover on your powered subwoofer or subwoofer amplifier.

Wiring Configurations Cont.

Passive Subwoofer Wiring - Bridged Output

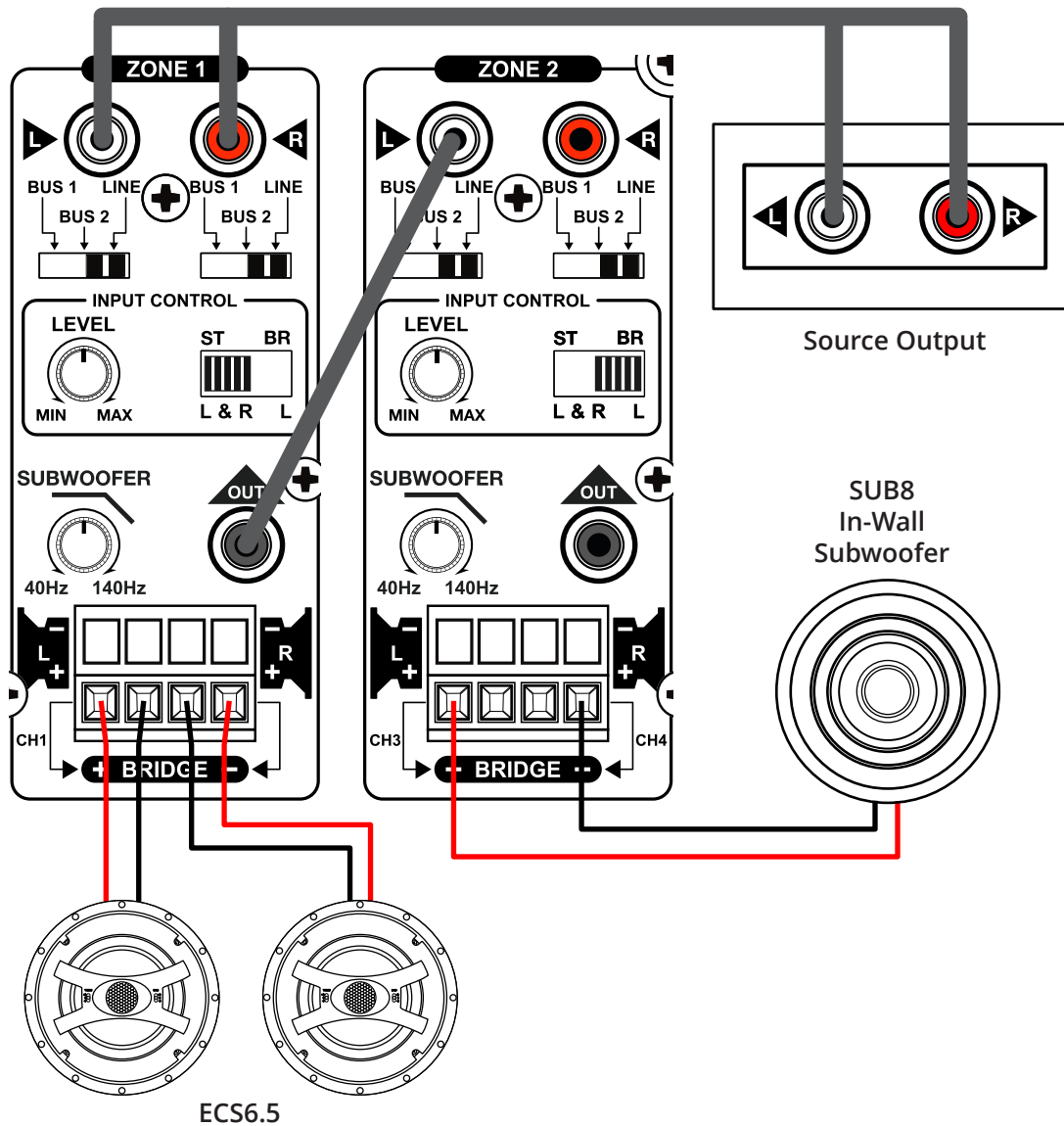

1. Attach your source to the LINE IN or BUS IN.
2. Set the input switch to the desired source.
3. Connect a single RCA wire from the SUB OUT of one zone to the next zone's LINE IN LEFT channel.
4. Connect the speakers to the phoenix connector of the first zone and set it to ST Stereo. Then connect the passive subwoofer to the outermost portions of the phoenix connector on the subwoofer zone and set it to BR Bridged.
5. Adjust the crossover and gain knobs on both zones until preferred music and subwoofer sound are achieved and use the source volume to adjust the sound level.

NOTE: The minimum impedance for bridging the channels on the Cin nova 12 is 8-Ohm.

Wiring Configurations Cont.

Dual Passive Subwoofer Wiring - Bridged Output

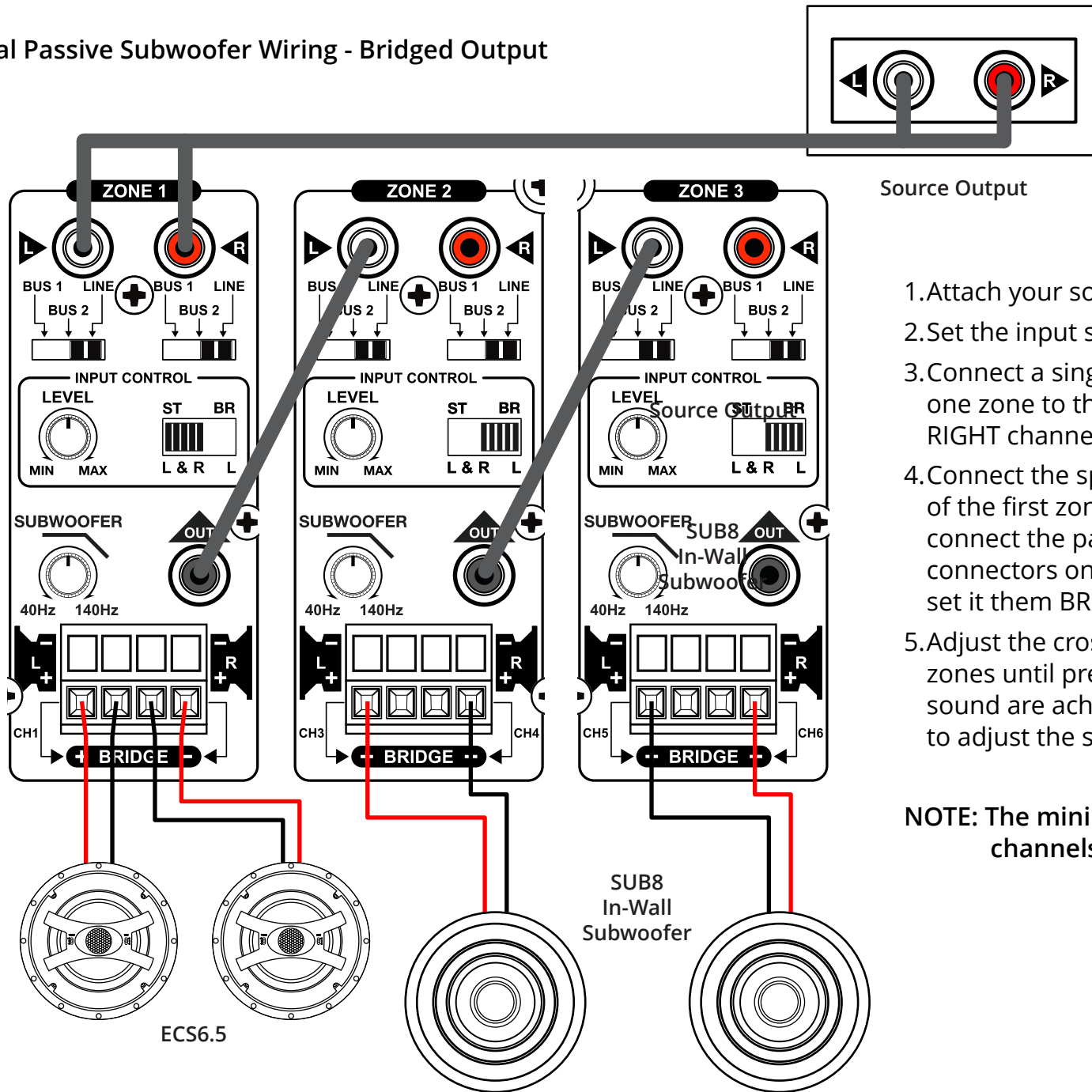

Source Output

1. Attach your source to the LINE IN or BUS IN.
2. Set the input switch to the desired source.
3. Connect a single RCA wire from the SUB OUT of one zone to the next zone's LINE IN LEFT and RIGHT channels.
4. Connect the speakers to the phoenix connector of the first zone and set it to ST Stereo. Then connect the passive subwoofers to the phoenix connectors on the two subwoofer zones and set them BR Bridged.
5. Adjust the crossover and gain knobs on both zones until preferred music and subwoofer sound are achieved and use the source volume to adjust the sound level.

NOTE: The minimum impedance for bridging channels on the Cinénova 12 is 8-Ohm.

Wiring Configurations Cont.

Outputting A Mono Signal Using BUS IN & OUT

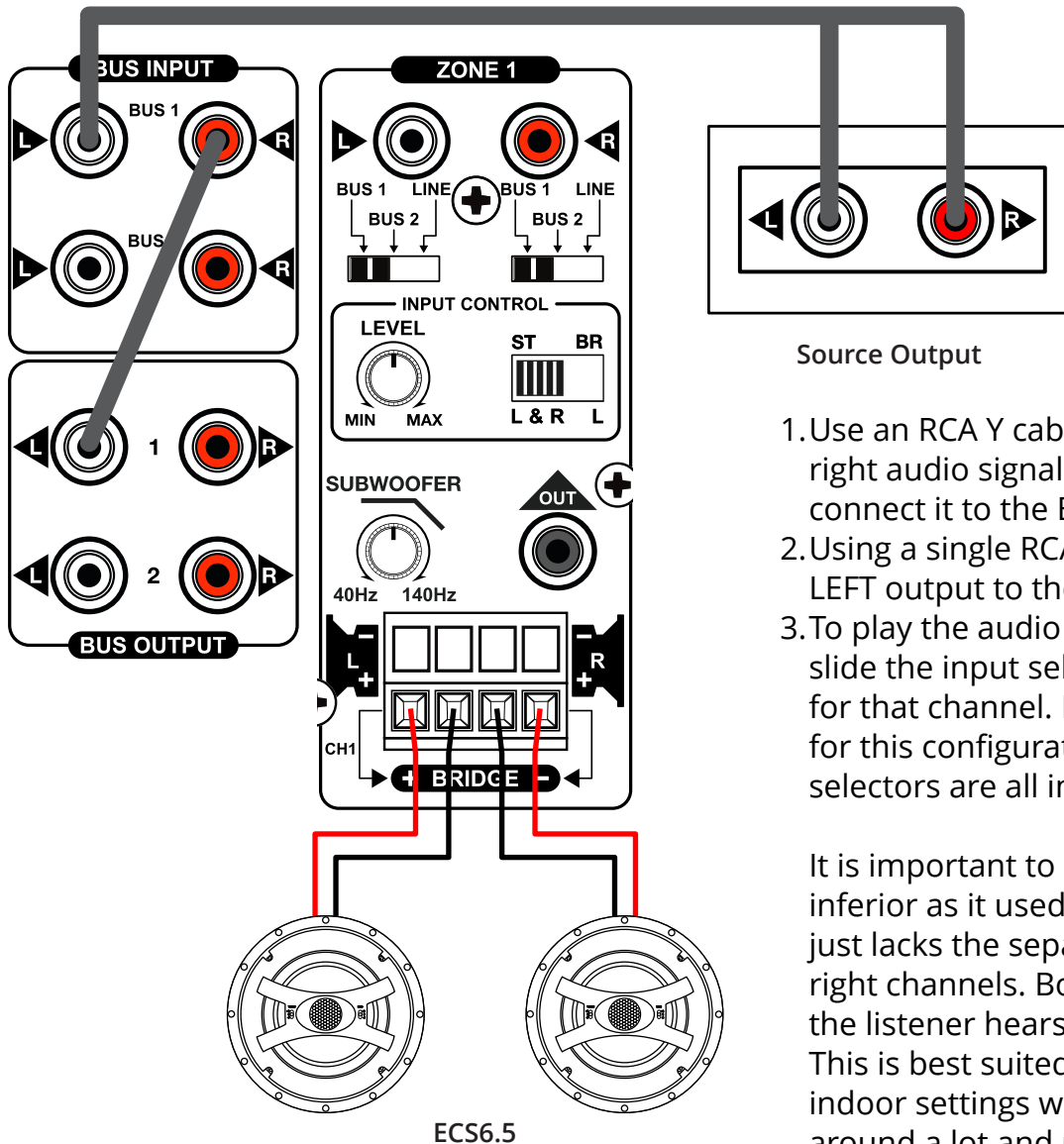

Source Output

1. Use an RCA Y cable to combine the left and right audio signals from your source. Then, connect it to the BUS 1 LEFT input.
2. Using a single RCA cable, connect the BUS 1 LEFT output to the BUS 1 RIGHT input.
3. To play the audio source through any speaker, slide the input selector to the BUS 1 position for that channel. If multiple zones will be used for this configuration, make sure that the input selectors are all in the BUS 1 position.

It is important to note that mono sound is not inferior as it used to be in the past; it simply lacks the separation of both the left and right channels. Both channels are merged, and the listener hears them through one speaker. This is best suited for outdoor systems or indoor settings where the listener may move around a lot and not be in the sweet spot between both speakers.

Connecting Multiple Amplifiers

24 Channel / 12 Zone Setup

If connecting multiple Cinénova 12 amplifiers, run an RCA cable from one of the BUS OUTPUTS of AMPLIFIER 1 to a BUS INPUT of amplifier 2. This will supply the source signal to the additional amplifier. Ensure that the input selector switches on AMPLIFIER 2 are in the correct BUS INPUT position. Additionally, if you are going to be using the TRIGGER feature, run an additional 3.5mm trigger cable from the TRIGGER OUT of AMPLIFIER 1 to the TRIGGER IN of AMPLIFIER 2.

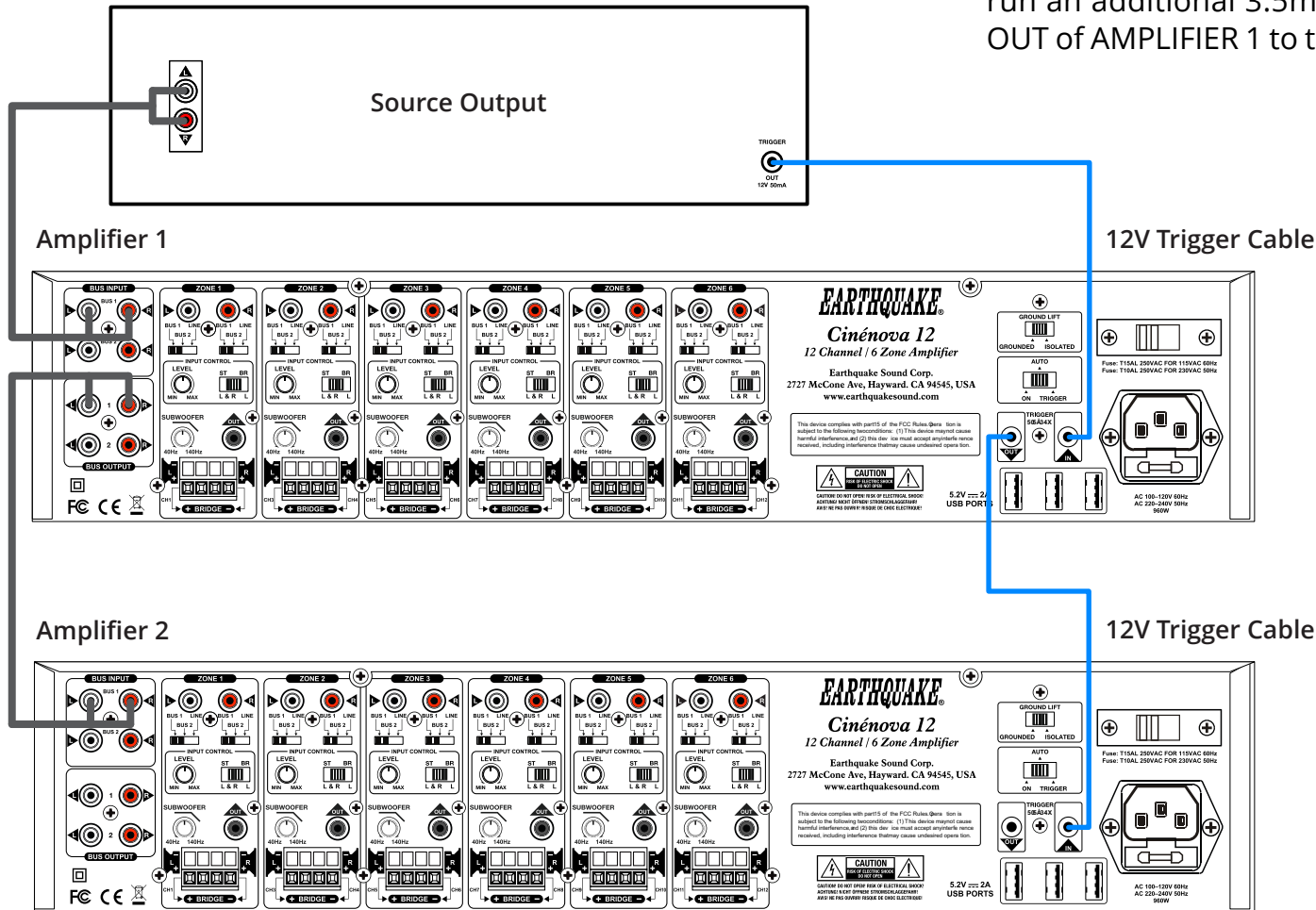

Cinénova 12 Specifications

- Number of Channels: 12-Channels / 6 Zones
- Power Rating Per Channel: 100W @ 4-Ohm
180W @ 8-Ohm Bridged
- Frequency Response: 20Hz-20kHz
- Total Harmonic Distortion - THD: <0.003% @ 1kHz
- Input Impedance: 20 kOhm
- Signal-to-Noise Ratio (A-Weighted): 110dB
- Auto OFF Delay Time: 15 minutes
- Crosstalk: 110dB Mono, 75dB Stereo
- Gain: 24dB
- Trigger In Voltage: 3.3-12V DC/AC
- Trigger Out Voltage: 12V DC
- Standby Power: 0.4W
- Power Requirement: 110-120V/60Hz, 220-240V/50Hz
- Fuse Rating: T15AL 250VAC For 115VAC 60Hz
T10AL 250VAC For 230VAC 50Hz
- Chassis Dimensions ($H_c \times W_c \times D_c$): 3.5" x 16.92" x 13.18"
89mm x 430mm x 335mm
- Mounting Dimensions ($H_M \times W_M$): 2.99" x 18.42" (76mm x 468mm)
- Overall Dimensions ($H_o \times W_o \times D_o$): 4.13" x 19.13" x 13.67"
105mm x 486mm x 347mm
- Net Weight: 33 lbs / 15 kgs
- Rack Spaces: 2U
- Rack Width: 19-Inches

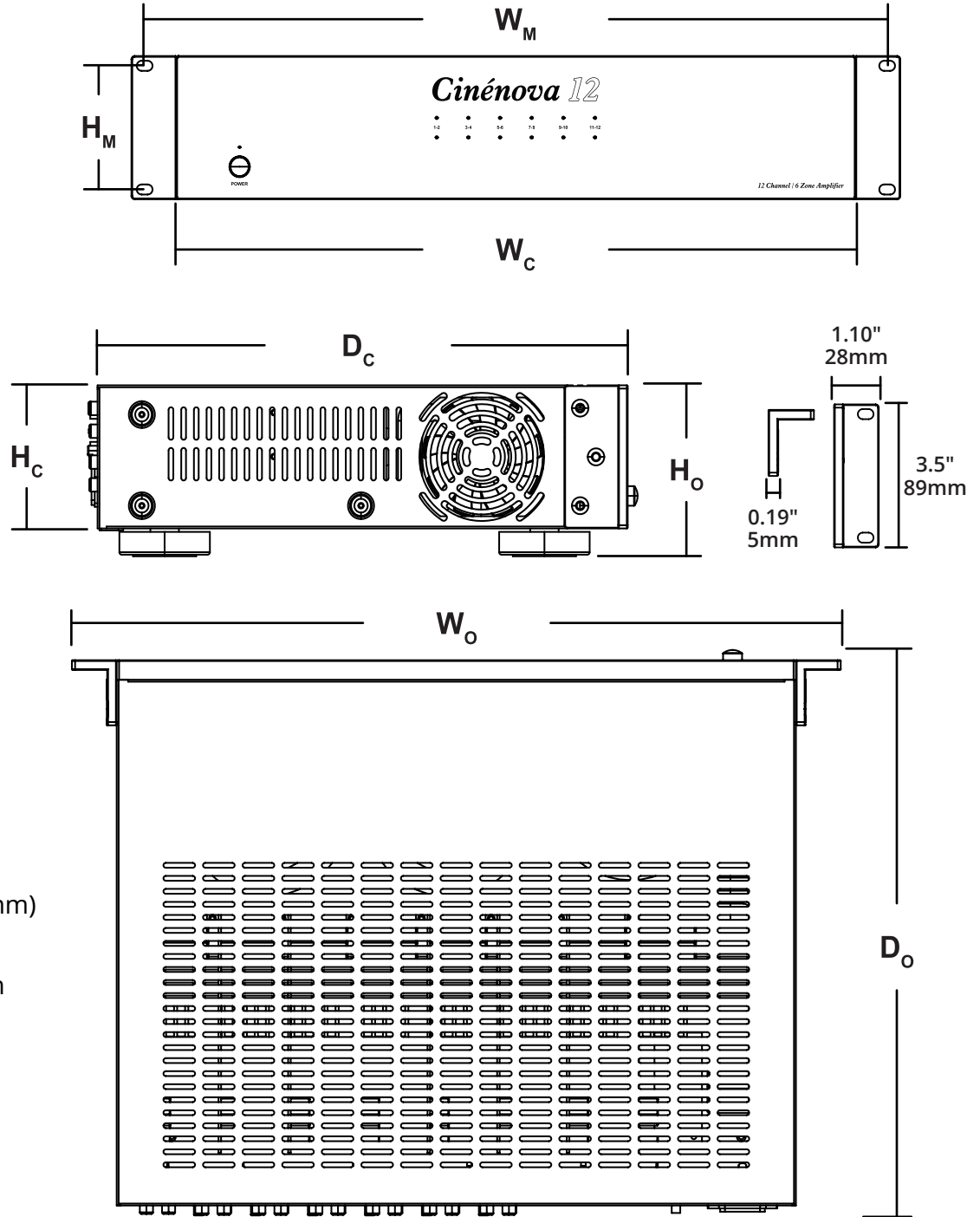

Troubleshooting The Cinénova 12

Front Panel LEDs

Each pair of channels or zones has a red and blue LED to indicate its operational status. These indicators provide quick and easy troubleshooting of the amplifier. In the event that the circuitry detects that a channel/s must be shut down due to excessive heat or low impedance (a short), only the affected channel/s will be turned off, forcing the zone LED to turn red. The remaining zones will continue to operate and maintain a blue LED status. Once the status has been corrected for the given zone/s, the status LED will return to blue. Note that the unit is in standby mode when the power LED is red, and the zone status LEDs are not illuminated (off).

Humming Noise From Speakers

Often humming noise is emanating from equipment that have their ground prong broken. To isolate this problem:

- a) With amplifier OFF, disconnect all RCA cables.
- b) Turn on amp and listen to speakers. If buzz has changed or reduced in level, then the problem is coming to the amp from another source. The rest of the hum you hear is normal and related to the fact that the RCA's are open ended.
- c) The above step should isolate your problem: star-ground all components, except amplifier, by daisy-chaining a thin wire from the processors chassis to all sources connected to it.

Speaker Impedance

Speaker Impedance	Standard Wiring	Number of Channels
One 8Ω Speaker	Ok	1
Two 8Ω Speakers	Ok	1
One 4Ω Speaker	Ok	1

Maintenance

The following maintenance should be performed routinely:

- a) Clean the exterior surfaces of the unit with a soft, dry, lint-free cloth.
- b) Do not use alcohol, benzene, acetone-based cleaners, or strong commercial cleaners.
- c) Do not use a cloth made with steel wool or metal polish.
- d) If the unit is exposed to a dusty environment, a low-pressure blower may be used to remove dust from its interior & exterior.

Circuit Protection

The Cinénova 12 is protected by anti-clipping circuitry that will automatically reduce the output level going to the speaker/s from the amplifier when it senses the volume is too loud. The RED clipping light will flash until you lower the source or the input gain control for that zone.

If Problems Persist

Contact Earthquake Sound Technical Service
Phone: 1-510-732-1000
Email: tech@earthquakesound.com

Speaker Impedance	Bridged Wiring	Number of Channels
One 8Ω Speaker	Ok	2
One Below 8Ω Speaker	Do Not Use	2

For Your Records

Date of Purchase: _____

Authorized Dealer/Installer Info:

Name: _____

Address: _____

Phone: _____

Serial Number:

Notes

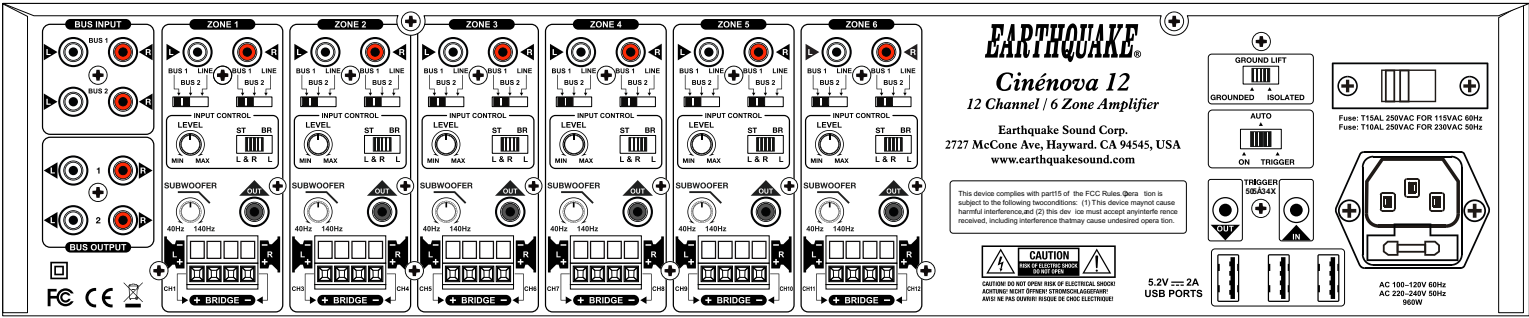
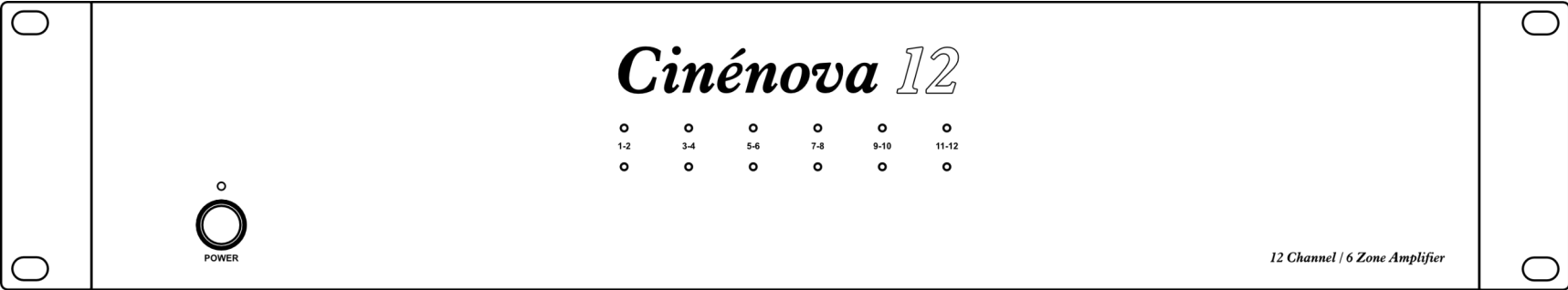



The Sound That Will Move You

Earthquake Sound reserves the right to amend details of the specifications without notice.

© Copyright Earthquake Sound Corporation

Earthquake Sound Corporation

2727 McCone Avenue, Hayward CA, 94545

Phone: (510) 732-1000 U.S. Toll Free: (800) 579-7944 Fax: (510) 732-1095