

EARTHQUAKE EARTHQUAKE® SOUND

The Sound That Will Move You



User Manual

Earthquake Sound Corp.
Phone: (510) 732-1000
www.earthquakesound.com
www.earthquakesoundshop.com

TABLE OF CONTENTS

Safety Instructions.....	3-5
Unpacking Tips.....	5
Introduction.....	6
What Makes A MiniMe DSP P63.....	7
Amplifier Plate Overview.....	8-9
Placing Your Subwoofer(s).....	10-11
Connecting Your Subwoofer(s).....	12
Room Tuning With iWoofers™ App.....	13-15
Dimensions And Specifications.....	16
Warranty Information.....	17-18
For Your Records.....	19



WARNING: This product is capable of generating high sound pressure levels. You should exercise caution when operating these speakers. Long term exposure to high levels of sound pressure will cause permanent damage to your hearing. Sound pressure levels exceeding 85dB can be dangerous with constant exposure. Set your audio system to a comfortable loudness level. Earthquake Sound Corp. Does not assume liability for damages resulting from the direct use of Earthquake Sound audio product(s) and urges users to play volume at moderate levels.



The Sound That Will *Move* You

Earthquake Sound Corporation
2727 McCone Ave. Hayward, CA 94545. USA
Tel: 510-732-1000

© 2023 Earthquake Sound Corporation. All rights reserved.

This document should not be construed as a commitment on the the part of Earthquake Sound Corporation. The information is subject to change without notice. Earthquake Sound Corporation assumes no responsibility for errors that may appear within this document.

SAFETY INSTRUCTIONS

SAFETY FIRST

This document contains general safety, installation, and operating instructions for the MiniMe DSP subwoofer. It is important to read this user's manual before attempting to use this product. Pay particular attention to the safety instructions.

SYMBOLS EXPLAINED



Appears on the component to indicate the presence of uninsulated, dangerous voltage inside the enclosure - that may be sufficient to constitute a risk of shock.



Calls attention to a procedure, practice, condition or the like that, if not correctly performed or adhered to, could result in injury or death.



Calls attention to a procedure, practice, condition or the like that, if not correctly performed or adhered to, could result in damage to or destruction of part or all of the product.

NOTE: Calls attention to information that is essential to highlight.

IMPORTANT SAFETY INSTRUCTIONS

- 1) Read these instructions in their entirety.
- 2) Store this manual and packaging in a safe place.
- 3) Read all warnings.
- 4) Follow instructions (do not take shortcuts).
- 5) Do not use this apparatus near water.
- 6) Clean only with a dry cloth.
- 7) Do not block any ventilation openings. Install in accordance with the manufacturer's instructions.
- 8) Do not install near any heat sources such as radiators, heat registers, stoves, or other apparatuses that produce heat.
- 9) Do not defeat the safety purpose of the polarized or grounding-type plug. A polarized plug has two blades with one wider than the other. The grounding-type plug has two blades and a third grounding prong. The wide blade or the third prong is provided for your safety. If the provided plug does not fit into your outlet, consult an electrician for replacement of the obsolete outlet.
- 10) Protect the power cord from being walked on or pinched, particularly at plugs, convenience receptacles, and the point where they exit from the apparatus.
- 11) Only use attachments and accessories specified by the manufacturer.
- 12) Use only a compatible rack or cart for the final resting position.

SAFETY INSTRUCTIONS CONT'D

- 13) Unplug this apparatus during lightning storms or when unused for a long period of time.
- 14) Refer all servicing to qualified service personnel. Servicing is required when the apparatus has been damaged in a way such as: power-supply cord or plug is damaged, liquid has been spilled or objects have fallen into the apparatus, the apparatus has been exposed to rain or moisture, does not operate normally, or has been dropped.
- 15) To reduce the risk of fire or electric shock, do not expose this apparatus to rain or moisture.

SYSTEM INSTALLATION CONSIDERATIONS

There are several factors to consider before installing or placing Earthquake Sound's MiniMe DSP Subwoofer.

What are the intended listening zones?

From where in each zone will the listener prefer to control the system? Where will the subwoofer be located?

Where will the source equipment be located?

CONNECTION TIPS

- Keep all power cords away from all signal cables to prevent humming from induced noise.
- Choose reliable signal cable cords (Earthquake Sound also specializes in high performance RCA cables and patches).
- All speaker wires that are ran through the walls should be twisted type to reduce potential hum noise pick-up.
- It is best to use a grounded electrical outlet to power the amplifier. Lack of input ground reference could be unsafe. Consult with your electrical contractor about proper grounding.

SAFE AND PROPER HANDLING

The MiniMe DSP P63 subwoofer can be moderately heavy for an average person to carry or maneuver. To prevent injuries and eliminate any possible damage to the subwoofer, we encourage you to seek help if needed when unpacking the unit. We further suggest the following.

- wear a back support belt if needed when carrying/lifting the MiniMe DSP P63.
- If possible, get someone to help you move the MiniMe DSP P63 subwoofer.
- Do not apply pressure or push against the face of the speaker as this will cause irreparable damage to the cone and suspension.

4 Specifications are subject to change without notice

SAFE AND PROPER HANDLING CONT'D

- When carrying the MiniMe DSP P63, make sure that the speakers/grilles are positioned away from your chest, eliminating the chance of pushing against the face of the speaker.
- Do not drop the MiniMe DSP P63 or subject it to sudden shocks. This will damage the external finish and weaken the enclosure, creating air leaks.
- Avoid exposing the MiniMe DSP P63 to moisture. Water will damage the wood structure as well as the amplifier and speaker.
- Cleaning the MiniMe DSP P63 is best using a soft cloth. If needed, use a mild detergent with water. Like any other electrical unit, always make sure that the unit is unplugged prior to cleaning it.

UNPACKING THE MINIME DSP

- Keep the original carton and packing materials for future shipment storage.
- Check for any visual signs of damage. If you encounter any concealed damage, consult your Earthquake Sound dealer before proceeding with unit installation.
- Retain the sales receipt as it establishes the duration of the limited warranty and provides information for insurance purposes.

The MiniMe DSP P63 is packaged well for safety. We highly suggest having a padded surface ready before unpacking the subwoofer.

STEP 1:

On a padded surface, carefully place the box on its side to remove the bottom packing tape and staples.



STEP 2:

Without tilting the box too much, tug the bottom flaps outward and keep the protective foam in place.



STEP 3:

Gently re-position the box upright.



STEP 4:

Slide the box off, minding the protective foam on the top, bottom, and sides of the subwoofer.



INTRODUCTION

Congratulations on your choice of Earthquake Sound's MiniMe DSP P63 subwoofer. The MiniMe DSP series of powered home subwoofers were designed to dramatically enhance your enjoyment of music and movies at home by adding power and impact to low frequency sound effects without taking up your entire living space. Congratulations and thank you for choosing the Earthquake Sound MiniMe DSP P63 subwoofer as a key component of your home audio system.

MiniMe DSP P63 subwoofers utilize an advanced digital class "D" amplifier, premium long throw active driver, and patented dual passive radiator technology. With a ported style design and piano gloss enclosure, the DSP P63 subwoofer delivers phenomenal bass. The iWoofers™ Pro interface conveniently allows for automatic professional room tuning for full DSP control all from mobile devices.

Designed in the U.S.A., The MiniMe DSP series of subwoofers meet and exceed industry standards of performance and quality. With uncompromising "World Class" performance and superior technology, MiniMe DSP subwoofers embody both power and elegance.

MiniMe DSP P63

***"The Most Powerful MF'ing Micro
Subwoofer On The Planet."***



**U.S. PATENT #11,140,474 B1 AND
OTHER PATENTS PENDING**

WHAT MAKES A MiniMe DSP P63

High Efficiency Class “D” Amplifier

The MiniMe DSP P63 amplifier utilizes an advanced class “D” circuitry with over 90% efficiency, allowing it to perform continuously without getting hot. A 600 watts peak power amplifier is fully equipped with auto room tuning adjustments, 0–180° phase switch, low level RCA inputs, auto signal sensing, and an app controlled DSP module.

Premium Active Long Throw Driver

The active driver installed in every MiniMe DSP P63 is specifically designed for accurate reproduction of bass and sub-bass frequencies. Built with TCT (Turbine Cooled Transducer) technology, stitched tensile leads, anti-wobble cone construction, and reinforced dust cap, the MiniMe DSP P63 driver effortlessly produces phenomenal bass with extremely low distortion while staying cool.

Dual Passive Bass Radiators

The MiniMe DSP P63 is equipped with two passive bass radiators. One is placed on each side of the active driver. This increases the efficiency of the subwoofer and capability of ultra-low frequency reproduction. Coupled with the active driver, the passive radiators allow the MiniMe DSP P63 to deliver louder and more powerful bass response without using more power from the amplifier.

Luxurious Piano Gloss Finish

The deep luxurious finish of the MiniMe DSP P63 begins with a thorough sanding and priming, followed by multiple applications of black or white piano lacquer with additional fine sanding between each layer and finished with a smooth, high gloss clear coat. Because the MiniMe DSP P63 has no visible grilles, the active and passive driver dust caps are finished with the same materials as the enclosure leaving it with a beautifully stunning and modern exterior that will complement any living space décor.

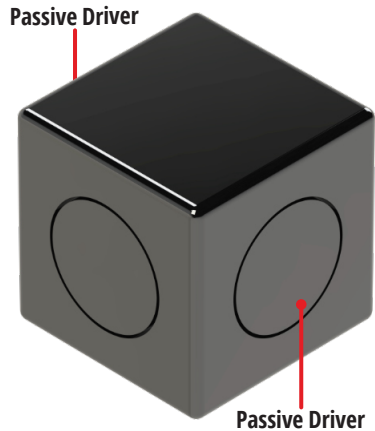
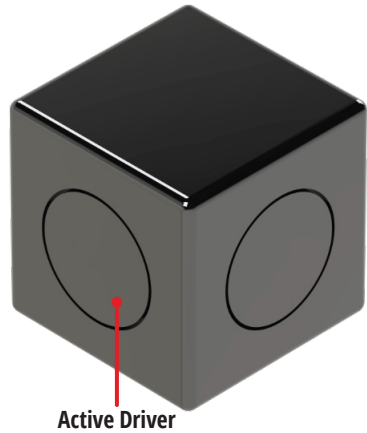

AMPLIFIER PLATE OVERVIEW

(1) DSP On/Off Switch

This switch is used to enable or disable the application controlled DSP. When set to the OFF position, the frequency adjustment knob will be active allowing the user to make manual adjustments. When enabled, make sure to adjust the volume control to half level.

(2) Auto/On/Off Mode Switch

This is a 3-way switch. When ON, the amplifier will remain on regardless of signal presence. When set to AUTO, the amplifier will only turn on when audio signal is detected. Additionally, the amplifier will go to sleep/standby if it does not detect any signal after 15 minutes. When set to OFF, the amplifier will remain off regardless of signal presence. Note that the MAIN POWER switch must be in the ON position in order for this feature to work.

(3) DSP LED

This LED indicator reflects the status of the on board DSP. When the DSP switch is set to the ON position the blue LED indicator will illuminate. Please note that while making any adjustments or saving presets in the iWoofer™ mobile app, you may see flickering from this LED indicator. This is considered normal as you are making on-the-fly adjustments to the amplifier.

(4) Power & Signal LED

This LED indicator reflects the main power status of the amplifier as well as the state of the MiniMe DSP P63 amplifier (whether the AUTO Sensing is on/off and whether signal is being fed to the amplifier). Note that this LED will only illuminate when the main power switch is set to the ON position.

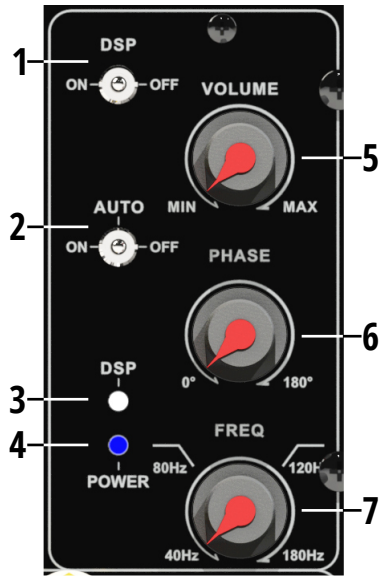

(5) Volume Control

This rotating knob allows users to control the volume of the subwoofer. Always start at the lowest setting and slowly increase the volume until the desired subwoofer level is reached. When DSP is enabled, adjust the volume control to half level.

(6) Phase Shift Control

This 0–180° switch allows the user to synchronize the subwoofer to obtain a better and more precise bass response.

(7) Low Pass Filter

A variable low pass filter from 40–180Hz is designed to control the cutoff frequency of the subwoofer. Any signals above the set crossover frequency will gradually roll off to prevent from interfering with your surround speakers. For 2.1 channel audio systems, Earthquake recommends that the filter be adjusted to the 80Hz position. For any other audio systems above 2.1 channels, it is highly recommended that the filter be adjusted to the 120Hz position.

AMPLIFIER PLATE OVERVIEW

(8) Low Level RCA Input

Use this input to deliver an audio signal from your A/V source to the MiniMe DSP P63 amplifier.

(9) 115V/230V AV Selector

The MiniMe DSP P63 can operate in a 110-120V or 220-240V environment. The subwoofer should be set to the correct voltage depending on your region. It is advised that you check the setting prior to connecting the subwoofer to any power source before use.

(11) Power Switch

Used to turn the MiniMe DSP P63 amplifier power on or off. Set this switch to the ON position in order to use the AUTO ON function as described in section (2).

(12) Main Power/IEC (2P) Power Cord Input

This AC line connector is used to power the subwoofer. Make sure that the power switch is in the OFF position prior to connecting the subwoofer to any power sources.

100-120V~60Hz
220-240V~50Hz

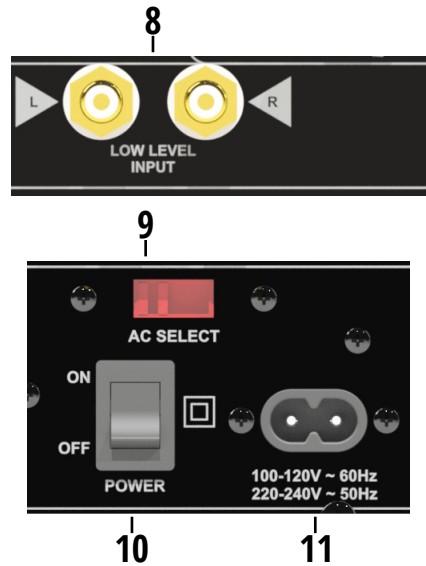

PLACING YOUR SUBWOOFER(S)

You often hear the term “subwoofers are non-directional.” This is not true. It is harder to choose subwoofer placement when low frequencies are crossed. The wider the room, the more directional the subwoofer. The easiest solution is to use two (2) subwoofers and feed a mono signal to both and place them in front, one on the left and another on the right.

While having two (2) subs is better than one, the MONO signal that drives those subs keeps them from projecting the three dimensional images in the sub-harmonics. Using two (2) subwoofers allows you to cross the subs up to 250Hz sound quality, imaging and staging. In some applications, you might have small front speakers or planar speakers. The two front-subwoofer system is an excellent solution to planar speakers' low frequency response early roll off from 150Hz on down. When placing these subwoofers in close proximity to the stereo satellite, the subs will enhance low frequency extension. It will be better to have a stereo subwoofer to help in the lower bass notes and their placement.

Suppose you have only one (1) subwoofer in the room and it is placed on the right side of the room. If a bass guitar player was standing on the left side of the stage and played a EE note (42Hz), then the sub will also respond to that from the right side of the room and completely destroy the stage.

You will see illustrations showing the two (2) different suggested setups. In each of them, note the breakaway and the image separation represented by the black and gray arrows.



The black arrows represent the sub-harmonic frequencies

The gray arrows represent the lows, mids, and highs as they follow the action.

The best response is achieved when the subharmonic frequencies are dynamically synchronized with the rest of the audio system, the black and gray arrows are identical.

Single Subwoofer Setup

This is a GOOD setup. The subharmonic frequencies (black arrow) always move towards the sub in the single sub setup while the lows, mids, and highs (gray arrow) follow the action.

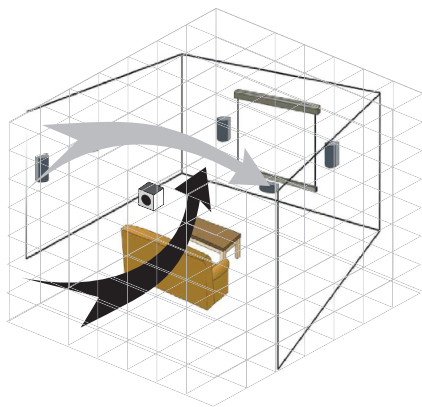

Placing the subwoofer in the corner of the room will produce a more boomy effect, often preferred for movies and sound tracks. For a music application, place the subwoofer as show above or against the front wall, about a third of the room width.

PLACING YOUR SUBWOOFER(S)

Dual Sub Setup With Mono Signal

This is a BETTER setup. In a dual sub-woofer setup, the sub-harmonic frequencies (black arrow) always move towards the middle of the room while the lows, mids, and highs follow the action (gray arrow).

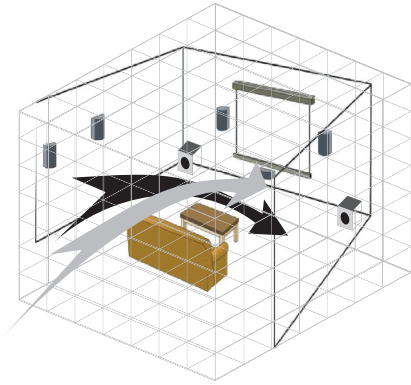

Notice the breakaway and image separation is less in this setup than the single subwoofer setup.

CONNECTING YOUR MINIME DSP P63 SUBWOOFER

Low Level RCA Setup - Single Subwoofer

This is the best way to drive an audio signal to your MiniMe DSP P63 subwoofer. Today, all signal processors (5.1, 6.1, etc.) come equipped with built-in pre-amplifier outputs (RCA) that include a subwoofer output. Generally, the SUB PRE OUT is in a mono format. Connect the SUB PRE OUT from your audio/video processor to the MiniMe DSP P63 LOW LEVEL INPUT using a "Y" RCA cable.

We strongly recommend that you use the best available RCA connectors and cables. High quality cables are normally triple shielded and the connectors are gold plated with forceful grasping.

When using this connection, the MiniMe DSP P63 only receives bass signals from the source. Therefore, the crossover frequency should be set at max value.

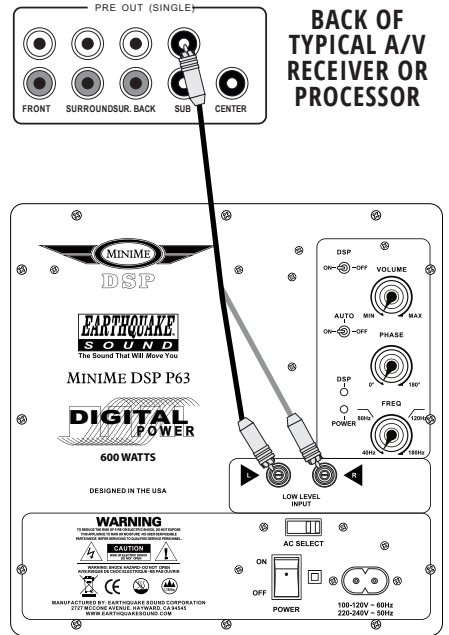

CONNECTING YOUR MINIME DSP P63 SUBWOOFER CONT'D

Low Level RCA Setup - Dual Subwoofers

For a more realistic sound stage and even greater theater experience, we suggest having two (2) subwoofers and running them in stereo.

Using a “Y” RCA cable, connect the SUB PRE OUT 1 of the receiver to the LOW LEVEL INPUT of the left side MiniMe DSP P63.

Using another “Y” RCA cable, connect the SUB PRE OUT 2 of the receiver to the LOW LEVEL INPUT of the right side MiniMe DSP P63.

In case the subwoofer/s become out of phase with the main front speakers, rotate the phase shift control to correct the problem. Note that maximum bass is only achieved when the subwoofer is in phase with the rest of the speakers in your audio system.

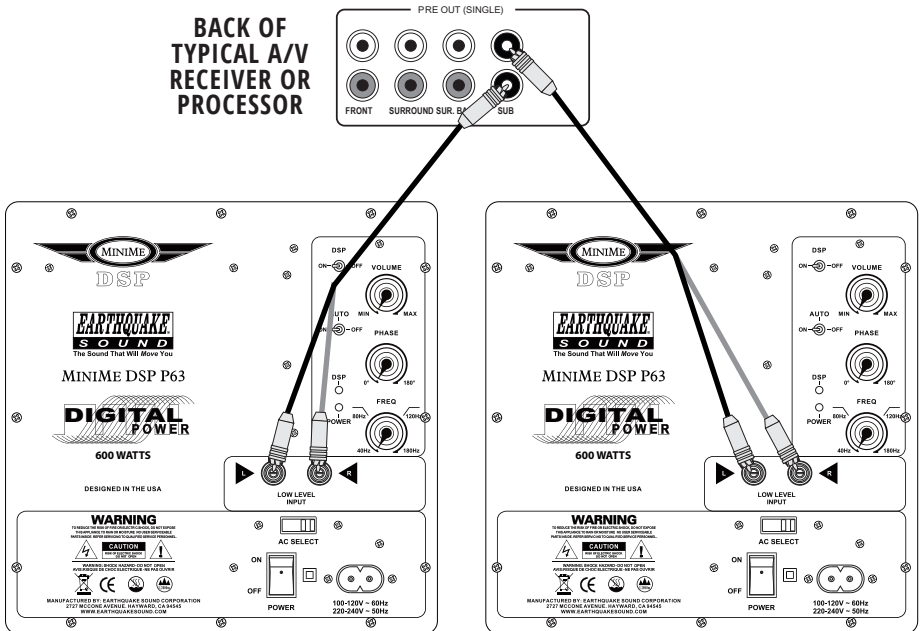

ROOM TUNING WITH iWoofers™

About iWoofers™

iWoofers™ is a mobile based application developed by ARTEM KHLIYUPIN, that allows the user to control DSP settings from a mobile device. In addition to full DSP control, the iWoofers™ Pro app offers automatic room correction to achieve a more linear or boomy response from the woofer.

Getting Started

Launch the iWoofers™ or iWoofers™ Pro app on your mobile device. Ensure that the iWoofers™ supported subwoofer is powered on and that Bluetooth is enabled on your mobile device. There is no need to search for the Bluetooth signal, the iWoofers™ app will automatically find it. Once the application has been launched, a list of devices found will appear as shown in the image. The device name is generally a string of letters and numbers representing the unique MAC or UDID address of the woofer you are connecting to. Alternatively, the “Demo Mode” can be used to test the app features without connecting to a woofer.

After selecting your device, you will be prompted to import a DSP preset. If no previous presets have been saved the the subwoofer, select “Cancel” to continue connecting, otherwise select “OK”. Your mobile device will now connect with the MiniMe DSP subwoofer. Once connected, the device can be re-named from the “Options” menu.

Main Menu

Once connected, the iWoofers™ application will automatically take you into the main menu. The iWoofers™ menu features and options are listed.

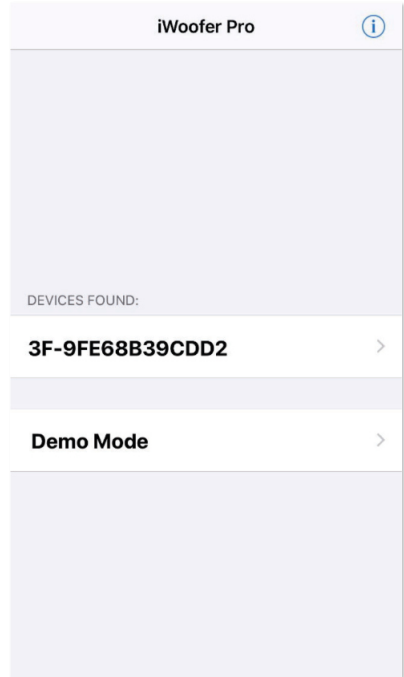

- XOver Control
- Gain Control
- SHS Control
- Delay Control
- Phase Control
- Limiter-Compressor Base Control
- Limiter-Compressor Detailed Control*
- Dynamic Bass Base Control
- Dynamic Bass Detailed Control*
- Remote Hardware Control
- Preset Manager
- Preset Import/Export Features
- Room Correction*
- SPL Meter*

*iWoofers™ Pro Features Only

ROOM TUNING WITH iWoofers™

Main Menu Cont'd



Xover Control

The XOver or Crossover control allows the user to control both the Low Pass and High Pass filters by double tapping the curve, or pressing and holding it for more than 1 second. The curve can then be slid left to right to control the frequency from 20Hz up to 500Hz. The curve can also be slid up and down to control the order of the filter up to an 8th order or 48 db/oct filter.

To add a fully Parametric Equalizer (PEQ), select the "+" icon. Up to 25 bands can be added, to remove a band, select the trash icon. Double tap or press and hold a band for more than one

second to select it. Once selected, slide the band left or right to change the frequency and up and down to control the gain. You can also use two fingers in a zoom in or zoom out fashion to change the Q factor, or PEQ bandwidth.

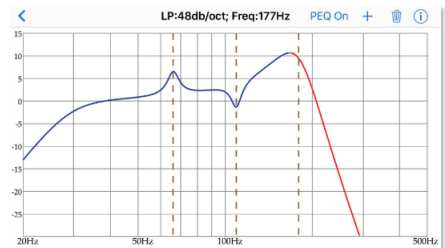
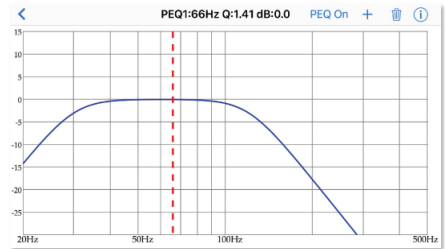
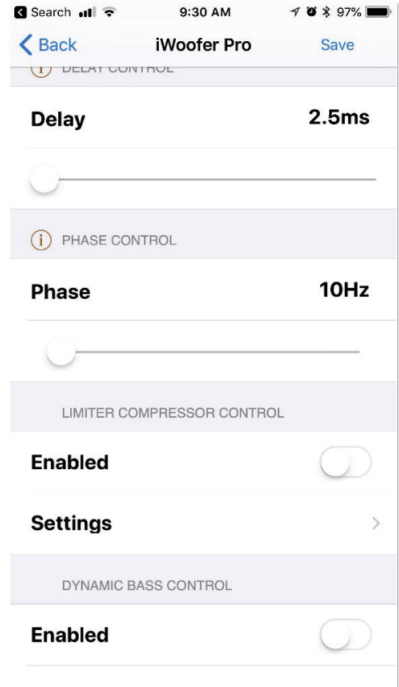

ROOM TUNING WITH iWoofers™

Room Correction Control

The iWoofers™ Pro app features automatic room correction. To begin, select “Room Correction” from the main menu. Once there, select “Wizard” to begin the automatic room correction process. Before beginning, ensure that the gain knob is properly adjusted on the woofer and that the sub is not over-driven.

iWoofers™ Pro will begin by taking a near field measurement. Place the microphone as close as possible to the subwoofer and equal distance from the passive side. This can best be done by placing the microphone so that it is facing the side of the subwoofer halfway between the active and passive. After placing your mobile device in the proper location, select “Next” to begin the sweep. It is important to remain silent during the sweeps. The subwoofer will now sweep through the frequency range. Once completed, you will be asked to add an additional response or sweep measurement or you may continue. It is recommended to perform a minimum of 3 response sweeps to get an accurate measurement.

Once you have obtained the desired sweeps select “No, Next” to continue to the next step. You will be prompted to select the reference type for the room compensation, Boomy Region, Near Field or Linear. We recommend the “Boomy Region” selection since it maintains the high energy peaks of the low frequencies while creating a linear response for the mid range. The Near Field option is ideal for users with poor mic tolerance as it measures relative SPL and only compensates for the room reflection. The final reference, Linear, creates as flat a response curve as possible throughout the frequency range.

After the desired option is selected, iWoofers™ will then instruct you to place the mic in your typical listening position. Once the mic is placed, click “Next”. The iWoofers™ Pro app will then proceed to sweep again. As before, we recommend performing at least 3 response sweeps. Click “No, Next” when you have concluded your response sweeps and iWoofers™ will proceed to make the necessary adjustments to your subwoofer’s response.

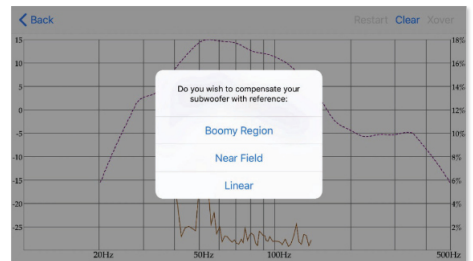
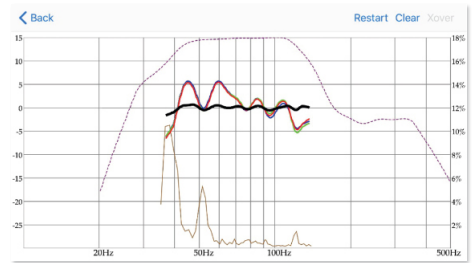
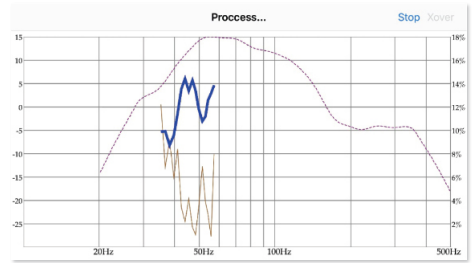

DIMENSIONS AND SPECIFICATIONS - MiniMe DSP P63

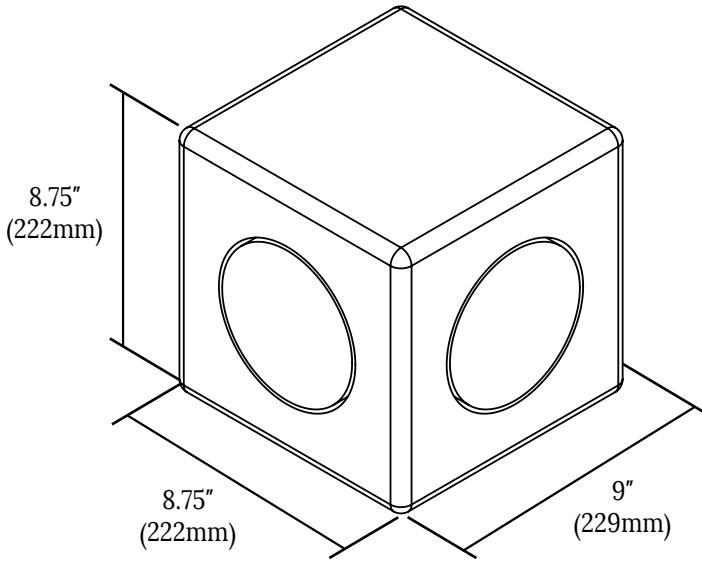

Enclosure Type	Dual Passive Tuned
Amplifier Power	600 Watts MAX
Drivers	Single 6.5" Premium Active Driver Dual 6.5" Passive Bass Radiators
Frequency Response	30Hz-160Hz
Crossover Frequency	40Hz-180Hz
Signal Sensing	AUTO/ON/OFF
Inputs	Low Level RCA Input
Other Features	Auto Room Tuning Adjustments 0-180° Phase Adjustment Control 110V/220V AC Selector iWoofers™ Compatible
Fuse Ratings	100-120V~60Hz 220-240V~50Hz
Dimensions (HxWxD)	8.75" (222mm) x 8.75" (222mm) x 9" (229mm)
Weight	13.84 lbs (6.27 kgs)

DIMENSIONS INCLUDE FEET AND AMPLIFIER PROTRUSIONS

WARRANTY INFORMATION

5 YEAR LIMITED WARRANTY INFORMATION

Earthquake Sound warrants the original purchaser that all Factory Sealed New Audio products be free from defects in material and workmanship, under normal and proper use, for a period of **five (5) year from the date of purchase** (as shown on the original sales receipt with serial number affixed/written on it). The one (1) year warranty period is valid only if the product is properly installed by an Earthquake Sound authorized party and the warranty registration card is properly filled out and sent to Earthquake Sound Corporation. If the product is installed by a non-authorized party, a thirty (30) day warranty period applies.

(A) Five (5) year limited warranty guidelines:

- **First Year:** Earthquake pays for labor, parts and ground freight (US Mainland only, not including Alaska and Hawaii.) Shipping to us is not covered.
- **Second, Third, Fourth, & Fifth Year:** Earthquake pays labor only. Customer must pay for parts and freight both ways.

(B) Warning:

- Products (sent for repair) that are tested by Earthquake technicians and deemed to have no problem(s) will not be covered by the limited warranty. Customer will be charged a minimum of one (1) hour of labor (at ongoing rate) plus the shipping charges back to the customer.
- Each product sent in for repair must be packaged in its original packaging. Otherwise, **repackaging charges will apply in addition to the labor, parts, and shipping charges.**

(C) Earthquake agrees to repair or replace - at our discretion - all such defective products/parts subject to the following provisions:

- Defective products/parts have not been altered or repaired by other than an Earthquake factory approved technician.
- Products/parts are not subjected to negligence, misuse, accident, or damaged by improper line voltage.
- Products/parts were used with incompatible products.
- The serial number or any part of the product has been altered, defaced, or removed.
- Products/parts have been used in any way that is contrary to Earthquake's written instructions.

(D) Warranty Limitations:

Earthquake warranty does not cover products that have been modified or abused, including but not limited to the following:

- Damages due to misuse, abuse or use of improper cleaning materials/methods
- Bent speaker frame, broken connectors, hole(s) in speaker cone, hole(s) in surround or dist cap, and burnt speaker voice coil.
- Fading and/or deterioration of speaker components & finish due to improper exposure to elements.

WARRANTY INFORMATION CONT'D

- Burnt tracers on PCB
- Product/part damaged due to poor packaging or abusive shipping conditions
- Subsequent damage to other products

A warranty claim will not be valid if the warranty registration card is not properly filled & returned to Earthquake with a copy of the sales invoice.

(E) Service Request:

To receive product(s) service, contact Earthquake Sound's service department at (510) 732-1000 or tech@earthquakesound.com and request an RMA (Return Material Authorization) number as item(s) shipped without a valid RMA number will be refused. Make sure you provide us with your complete and correct shipping address, a valid daytime phone number, and a brief description of the problem you are experiencing with the product. In most cases, our technicians might be able to resolve the problem over the phone or via e-mail, thus eliminating the need to ship the product.

(F) Shipping Instructions:

Product(s) must be packaged inside its original protective box(es) to minimize transportation damage. Shipper claims regarding items damaged in transit must be presented to carrier. Earthquake Sound Corporation reserves the right to refuse improperly packaged product(s). A copy of the original sales receipt must accompany the product(s) returned for service. Ship the product(s) to:

Earthquake Sound Corporation. 2727 McCone Avenue. Hayward, CA 94545

The customer is responsible for the cost of shipping the product(s) to Earthquake Sound Corporation

(G) Disputes Resolution:

All disputes - between clients and Earthquake Sound Corporation - resulting from the one (1) year limited warranty policy must be resolved according to the laws & regulations of the county of Alameda, California.

FOR YOUR RECORDS

Date of Purchase: _____

Authorized Dealer/Installer Info:

Name: _____

Address: _____

Phone: _____

Serial Number:

Notes:



The Sound That Will Move You

Earthquake Sound reserves the right to amend details of the specifications without notice

@ Copyright Earthquake Sound Corporation

www.earthquakesound.com

www.earthquakesoundshop.com

2727 McCone Avenue, Hayward, CA 94545 USA

Phone: 510-732-1000