



The Sound That Will Move You

# QUAKE

## Tactile Transducer Systems



Q10B

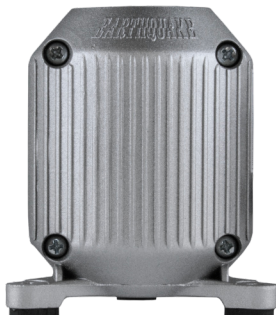

MQB-1

## Installation Manual

[www.earthquakesound.com](http://www.earthquakesound.com)

**By now, you may have some knowledge about Tactile Transducers. To help clarify this application further, please read on:**

## **What is a Tactile Transducer?**

A tactile transducer or "bass shaker" is a device which is made on the principle that low bass frequencies can be felt as well as heard. A shaker transmits low-frequency vibrations into various surfaces so that they can be felt by people. This is called tactile sound. Tactile transducers may augment or in some cases, substitute for a subwoofer.

Tactile transducers may be used in a home theater, a commercial movie theater, or for special effects in an arcade game, amusement park ride or other application.

## **In Home Theater and Music Applications:**

A surround sound audio system complements a video action movie by responding to the events that are unfolding on the screen. The surround sound extends from 30Hz (if you are lucky) and up to 20Khz. For the most part, it is the low frequency response that brings you closer to the action. A tactile transducer system will tap into the low frequency signal that is emanating for LFE output, which is typically located in the back of your AV receiver. This signal is amplified through a resilient power amplifier and then used to drive the tactile transducer; Thus, picking up and enhancing everything your subwoofer lacks.

## **In Gaming Applications:**

Tactile transducers are an explosive way to generate massive vibration, which brings players into the video game. Mounting an MQB-1 in a gamer seat will lead to an incredible interactive experience unlike any other.

# Earthquake Tactile Transducers Basic Information

## In Music Applications:

Music recordings can be immensely enhanced by allowing musicians (drummers in particular) who rely on sound and impact to literally feel their progress while recording. Now, musicians can rely on tactile transducers to transmit vibrations through their seats. The vibration allows them to actually feel the beat more naturally and confidently synchronize it with others in the band.

## Mounting Quake Tactile Transducers:

The Earthquake Q10B and MQB-1 need to be mounted vertically at all times. Mounting them vertically maximizes the output and increases the over all tactile experience.

Horizontally mounting the units will diminish the output and may damage them over time.



**Patent No: US 7,449,803 B2**  
**US 7,768,160 B1**  
**US 7,859,144 B1**

# Connecting Earthquake Tactile Transducers

## Tools/supplies that will be needed for installation:

- 16 to 12 gauge speaker cable
- A pair of pliers
- A powered screw driver
- Measuring tape
- Two (2) wing nut wire connectors or electrical tape

## Connecting 1 MQB-1 to an XJ-300ST amplifier

**NOTE:** Make sure the amplifier's front toggle switch is set to LOWPASS" prior to connecting the tactile transducers.

**WARNING** F q'p'q'v' k'g'3'D'S'D/3'y' k'j' v'j' g'b' q'p'q'v'k'f' i' g'v'g'v'k'p'i' 0'W'ug'g'k'j' g't' v'j' g'N'gh'v'k't' T' k' j' v'v'ur' g'c'm'g't' q'w'w' w'0

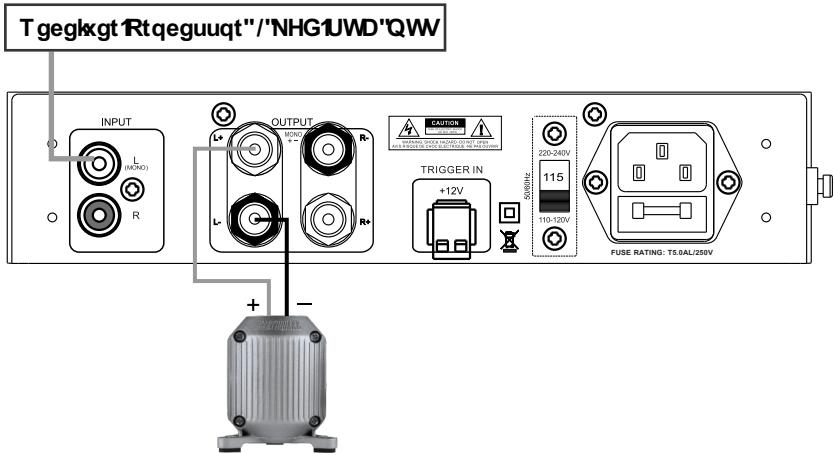

# Connecting Earthquake Tactile Transducers

## Connecting 2 MQB-1 to an XJ-300ST amplifier

**NOTE:** Make sure the amplifier's front toggle switch is set to **LOWPASS** prior to connecting the tactile transducers.

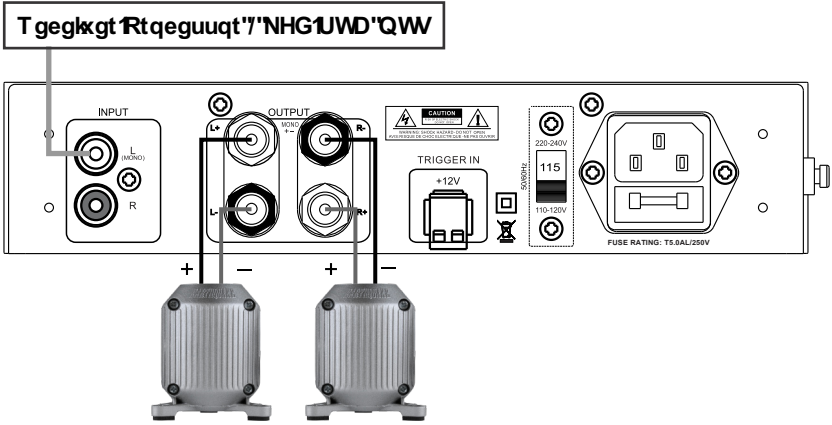

## Eqppgevpi '3'S 32D'q'cp'ZL/522UV'bo r rkg

PQVG<Ocnq'lwrg'yj g'bo r rkg'at'it'qp'v'qj i ng'uy kej 'ku'ug'v'q'UNQY RCUE  
r tkt'q'eqppgevpi 'yj g'v'ce'v'g'v'cpuf wegtu0

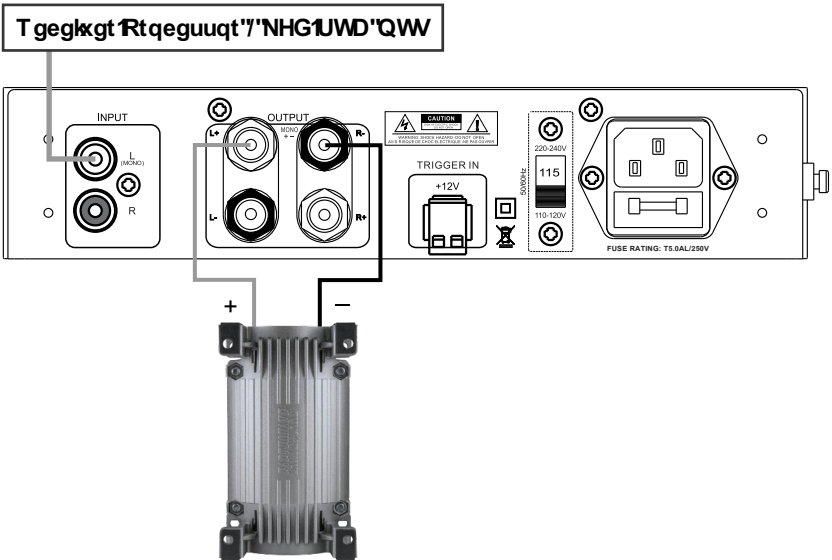

# Installing/Mounting Earthquake Tactile Transducers

## Applications:

Sofas  
Theater seats  
Recliners  
Gaming Chairs

## Type of Mounting:

Direct  
Multiplier  
Internally  
Externally

## Enhancements To:

Musical Enjoyment  
Home Cinema/Theater  
Gaming Experience  
Recording Studio

### Mounting the MQB-1 to Seating Directly

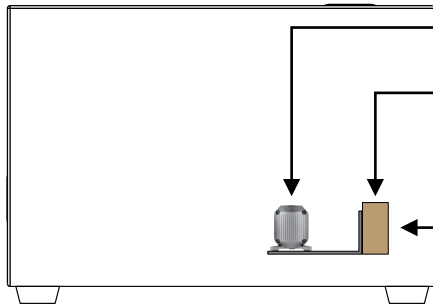

MQB-1

MQB-1  
Mounting Bracket

Strongest Joist / Brace  
in Sofa or Chair

### Mounting the Q10B to Seating Directly

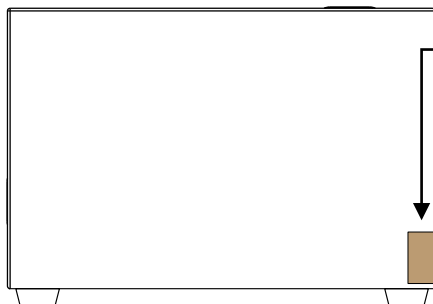
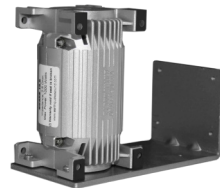

Strongest Joist / Brace  
in Sofa or Chair

Q10B  
Mounting Bracket

Q10B

# Installing/Mounting Earthquake Tactile Transducers

## Mounting the Q10B to a Platform

When designing your custom platform, be sure to allow 1-1/2 to 2 feet of space around the outer perimeter of the chairs or sofa. This much space is not required in between the chairs.

All platforms should be constructed with no less than 1/2" plywood and built sturdy for some seriously high speed entertainment. Also, the use of rubber stabilizers is an excellent way to eliminate rattles and vibrations that may cause valuables to fall off the walls or shelves. In addition, the rubber feet will provide a great suspension, allowing the Q10B to really shine.

The optional PB-1 Multiplier Bracket can be installed underneath or inside couches or chairs as in previous illustrations, but it is more effective when mounted directly to the platform. Once the PB-1 bracket is mounted to the platform, you may then move a chair or couch over it for a more plush cosmetic appearance.

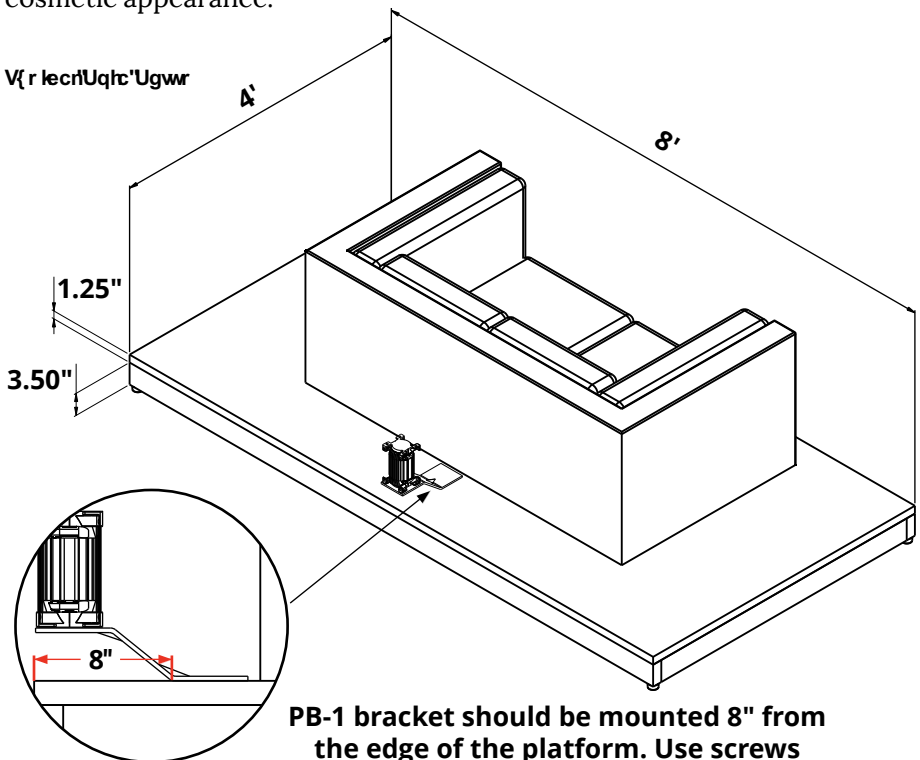

# Installing/Mounting Earthquake Tactile Transducers

## Oqwpvpi 'vj g'OSD/3'vq'l co lpi 'Ej ck

Pre-built gaming chairs come in all different shapes and sizes. The illustration to the right is only a demonstration on how you may install a MQB-1 to this type of application. Always be sure that what you are mounting the bracket to is very solid and won't pierce any pre-existing wiring or damage the chair's upholstery. In addition, please keep in mind that the MQB-1 is very powerful and will deteriorate poorly constructed chairs, thrones, etc. You may even need to modify existing construction.

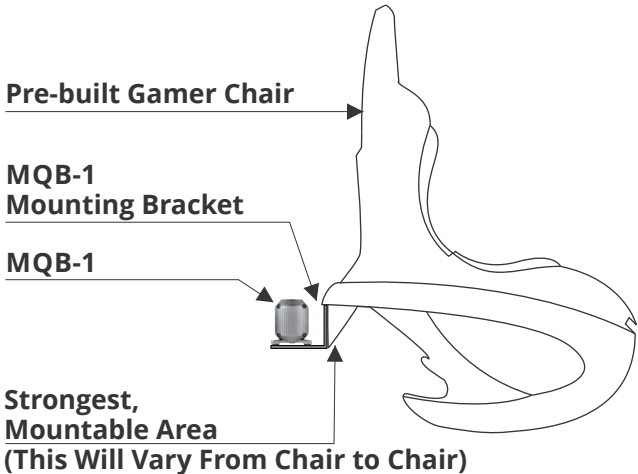

## Oqwpvpi 'vq'Q eg'Ej ck'qt'Vj tqpg

For rotating office chair or throne, we suggest using the **Shell Shoxx** system which includes the **MQB-XX** shaker and **300-XX**, a matching 300 watts max amplifier. This gaming set is the ultimate gaming accessory and brings 3D Motion™ to any gaming rig.

The MQB-XX is a patented shaker that converts low frequencies into powerful vibrations. It is optimized to clamp onto virtually any office chair; however, can be clamped onto an ordinary chair leg or couch structure as well. The MQB-XX is powered by our 300-XX, an amplifier specifically designed for our shaker.





# Earthquake Tactile Transducers Specifications

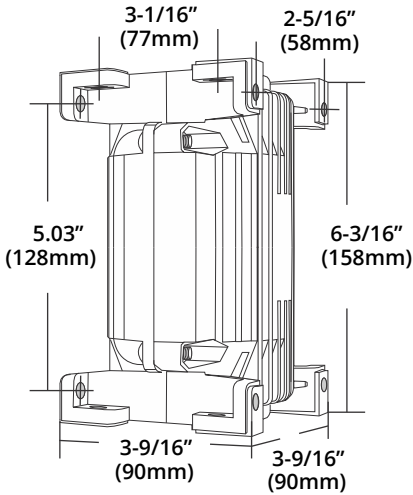

## Q10B

Frequency Response: 5Hz-40Hz  
Nominal Impedance: 5.4 Ohm  
Power Handling: 40-1000 Watts

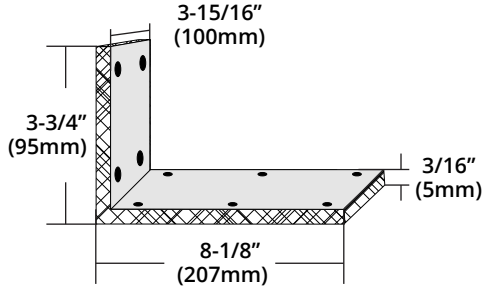

## OSD/3

Frequency Response: 15Hz-50Hz  
Nominal Impedance: 5.4 Ohm  
Power Handling: 20-500 Watts

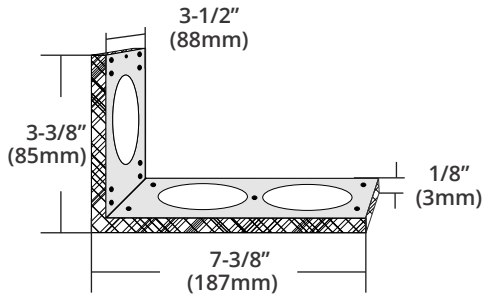
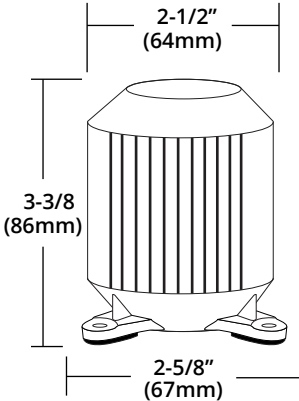

3-15/16" (100mm)

## PB-1 Multiplier Bracket

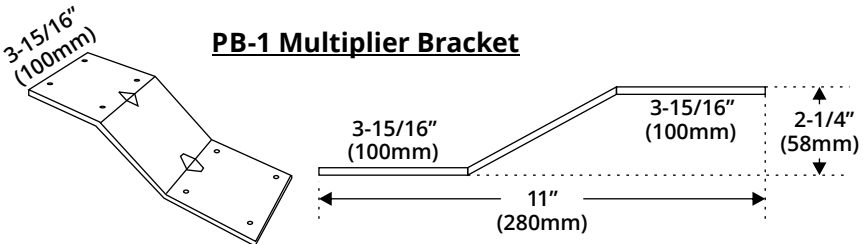

## Five (5) Year Limited Warranty Guidelines

Earthquake warrants the original purchaser that all Factory Sealed New Audio Products be free from defects in material and workmanship, under normal and proper use, for a period of five (5) years from the date of purchase (as shown on the original sales receipt with serial number affixed/written on it).

The five (5) years warranty period is valid only if the product is properly installed by an Earthquake authorized dealer/installer, and the warranty registration card is properly filled out and sent to Earthquake Sound Corporation. If the product is installed by a non-authorized dealer/installer, a ninety (90) days warranty period applies.

### **(A) Five (5) years limited warranty plan coverage guidelines:**

- First year: Earthquake pays for labor, parts, and ground freight (only in US mainland, not including Alaska and Hawaii) back to customer.
- Second, third, fourth & fifth year: Earthquake pays labor only. Customer must pay for parts and freight both ways.

### **(B) Warning:**

Products (sent for repair) that are tested by Earthquake technicians and deemed to have no problem, will not be covered by the five (5) years limited warranty. Customer will be charged a minimum of one (1) hour of labor (ongoing rates) plus shipping charges back to customer.

### **(C) Earthquake agrees to repair or replace - at our option - all such defective products/parts subject to the following provisions:**

- Defective products/parts have not been altered or repaired by other than an Earthquake factory approved technician.
- Products/parts are not subjected to negligence, misuse, improper use, or accident, damaged by improper line voltage, used with incompatible products, or have its serial number or any part of it altered, defaced, removed, or have been used in any way that is contrary to Earthquake's written instructions.

### **(D) Warranty Limitations:**

Earthquake warranty does not cover products that have been modified and/or abused, including but not limited to the following:

- Damages to speaker cabinet and cabinet finish due to misuse, abuse, or improper use of cleaning materials/methods.
- Bent speaker frame, broken speaker connectors, holes in speaker cone, surround & dust cap, burnt speaker voice coil.

## Five (5) Year Limited Warranty Guidelines

- Fading, deterioration of speaker components & finish due to improper exposure to elements.
- Bent casing, damaged finish on the casing due to abuse, misuse, or improper use of cleaning material.
- Product/part damaged due to poor packaging or abusive shipping conditions.
- Subsequent damage to other products

A warranty claim will not be valid if the warranty registration card is not properly filled & returned to Earthquake with a copy of the sales receipt.

### **(E) Service Request:**

To receive product(s) service, contact Earthquake Sound's service Department at (510) 732-1000 and request an RMA number (Return Material Authorization), item(s) shipped without a valid RMA number will be refused. Make sure you provide us with your complete and correct shipping address, a valid phone number, and a brief description of the problem you are experiencing with the product. In most cases, our technicians might be able to resolve the problem over the phone, thus eliminating the need to ship the product.

### **\*H#Shipping Instructions:**

Product(s) must be packaged in its original protective box(es) to minimize transport damage. Shipper claims regarding item(s) damaged in transit must be presented to the carrier. Earthquake Sound Corporation reserves the right to refuse improperly packed product(s). A copy of the original sales receipt must accompany product(s) returned for service. We encourage you to include a written description of the problem inside the package. Ship product to:

Earthquake Sound Corp.  
2727 McCone Avenue  
Hayward, CA 94545

You are responsible for the cost of shipping the product to Earthquake Sound Corporation.

### **\*I #Disputes Resolution:**

All disputes between clients and Earthquake Sound Corporation resulting from the five (5) years limited warranty policy must be resolved according to the laws & regulations of the county of Alameda, California.

### **For Technical Support**

E-Mail: [tech@earthquakesound.com](mailto:tech@earthquakesound.com)

Phone: 510-732-1000



*The Sound That Will Move You*

Earthquake Sound reserves the right to amend details of the specifications without notice.

Copyright © Earthquake Sound Corporation

Earthquake Sound Corporation • 2727 McCone Avenue Hayward CA, 94545

Phone: 510-732-1000 Fax: 510-732-1095