

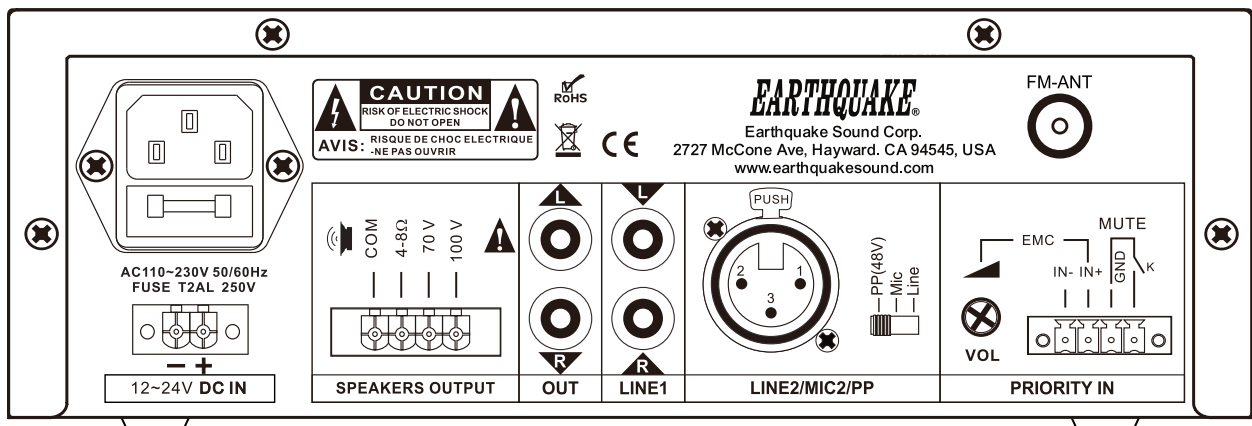

The Sound That Will Move You

MXA-100BT

70/100V Professional
Mixer Amplifier with Bluetooth®

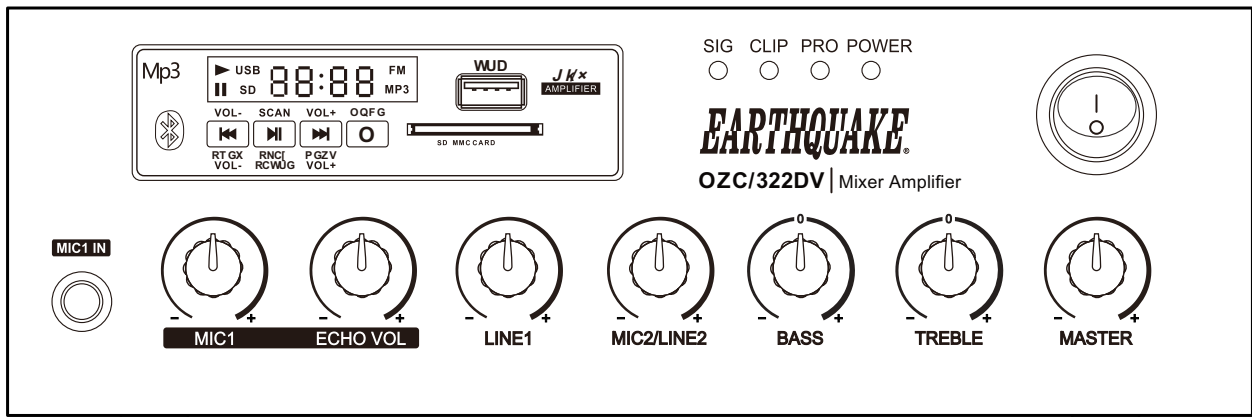

User Manual

Table of Contents

| | |
|------------------------------------|-------|
| Important Safety Instructions..... | 3 |
| Introduction & Features..... | 4 |
| Front Panel Overview..... | 5–6 |
| Rear Panel Overview..... | 7 |
| Notices..... | 8 |
| Operation Guidelines..... | 9–12 |
| Connections & Specifications..... | 13 |
| Troubleshooting..... | 14 |
| Warranty Information..... | 15–16 |
| For Your Records..... | 17 |
| Notes..... | 18 |

Customer Technical Support
Tel: 1-510-732-1000
tech@earthquakesound.com

Earthquake Sound Corporation
2727 McCone Avenue
Hayward, CA 94545
Tel: 1-510-732-1000



©2024 Earthquake Sound Corporation. All rights reserved.

This document should not be construed as a commitment on the part of Earthquake Sound Corporation.

The information is subject to change without notice.

Earthquake Sound Corporation assumes no responsibility for errors that may appear within this document.

WARNING: Earthquake Sound products are capable of generating high sound pressure levels and strongly encourage you to exercise caution during operation. Long term exposures to high levels of sound pressure will cause permanent damage to your hearing. Sound pressure levels exceeding 85dB can be dangerous with constant exposure. Set your audio system to a comfortable loudness level. Earthquake Sound Corp. does not assume liability for damages resulting from the direct use of Earthquake Sound audio product(s) and urges users to play volume at moderate levels.

 This device complies with part 15 of the FCC Rules. Operation is subject to the following two conditions: (1) This device may not cause harmful interference, and (2) this device must accept any interference received, including interference that may cause undesired operation.

Important Safety Instructions

- Read these instructions in their entirety.
- Store this manual and packaging in a safe place.
- Heed all warnings.
- Follow instructions (do not take short cuts).
- Do not use this apparatus near water.
- Clean only with a dry cloth.
- Do not block any ventilation openings and install in accordance with the manufacturers instructions.
- Do not install near any heat sources such as radiators, heat registers, stoves, or other apparatuses that produce heat.
- Do not defeat the safety purpose of the polarized or grounding-type plug. A polarized plug has two blades with one wider than the other. A grounding-type plug has two blades and a third grounding prong. The wide blade or the third prong is provided for your safety. If the provided plug does not fit into your outlet, consult an electrician for replacement of the obsolete outlet.
- Protect the power cord from being walked on or pinched, particularly at plugs, convenience receptacles, and the point where they exit from the apparatus.
- Only use attachments & accessories specified by the manufacturer.
- Use only with a cart, stand or table that can support the product weight, NOT RACK MOUNTABLE. Use caution when moving or positioning your rack or cart so that it will not tip over, which may cause serious injury to you or your products.
- Unplug this apparatus during a lightning storm or when unused for long period of time.
- Refer all servicing to qualified service personal. Servicing is required when the apparatus has been damaged in any way such as: power-supply cord or plug is damaged, liquid has been spilled or objects have fallen into the apparatus, the apparatus has been exposed to rain or moisture, does not operate normally, or has been dropped.
- To reduce the risk of fire or electric shock, do not expose this apparatus to rain or moisture.

The following symbols are used in this document:



Appears on the component to indicate the presence of uninsulated, dangerous voltage inside the enclosure – voltage that may be sufficient to constitute a risk of shock.

CAUTION

Calls attention to a procedure, practice, condition or the like that, if not correctly performed or adhered to, could result in injury or death.

WARNING

Calls attention to a procedure, practice, condition or the like that, if not correctly performed or adhered to, could result in damage to or destruction of part or all of the product.

Note: Calls attention to information that is essential to highlight.

Introduction

The Earthquake MXA-100BT Mixer Amplifier with Bluetooth delivers 60W RMS of power, ideal for various settings like schools, supermarkets, banks, and hotels for background music and public address. This all-in-one device combines a media player, preamp, and mixer power amplifier in a single unit. It consolidates audio sources with MIC1 and MIC/LINE inputs, a Tel input, and line output. The MIC1 VOX feature enhances functionality, while an FM tuner, USB, SD card slot on the front panel ensure easy accessibility. 100V / 70V / 4–8 Ohm speaker outputs allow for multiple connections, and protection mechanisms ensure safety. The MXA-100BT, featuring echo effects, is well-suited for diverse applications and supports both AC 230V and 12-24V DC power supply systems, making it adaptable for mobile sound systems in vehicles or vessels.

Features

- Compact size suitable for background music and public address systems
- Built-in media player with Bluetooth v5.2, USB/SD Mp3 player, FM radio tuner
- 60W rated power output
- 70V, 100V, and 4–8 Ohm speaker output options
- Included IR remote for front panel media player
- Power, clip, protection, and signal LED indicators
- Front panel 1/4 in. (6.3mm) microphone jack input
- Switchable MIC2/LINE2 balanced XLR input with +48V phantom power
- RCA LINE1 input and RCA LINE output
- MUTE and EMC priority inputs for AUX signal
- Front MIC, ECHO, LINE, and MASTER volume controls
- Front BASS and TREBLE tonal controls
- Short, clip, overload, and thermal protection circuitry
- 110–230V AC and 12–24V DC power supply support
- Suitable for mobile vehicle or vessel audio applications

Product Contents

- (1) MXA-100BT Mixer Amplifier
- (1) 5 ft external FM antenna
- (1) IR remote
- (1) Power cable (NEMA 5-15P to C13)
- (1) User Manual

Front Panel Overview

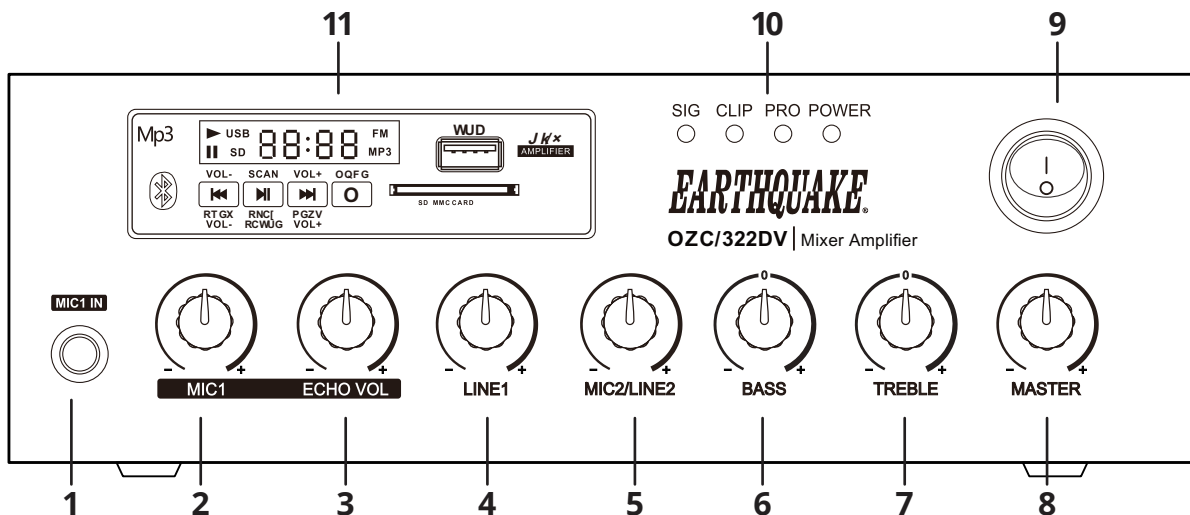

1. MIC1 Input

This input is designed for connecting a 1/4-inch (6.3mm) phone plug.

2. MIC1 Volume Control

This knob increases or decreases the volume of the MIC1 channel.

3. MIC1 Echo Volume Control

This knob increases or decreases the echo of the MIC1 channel.

4. LINE1 Volume Control

This knob increases or decreases the volume of channel LINE1.

5. MIC2/LINE2 Volume Control

This knob increases or decreases the volume of channel MIC2/LINE2.

6. BASS Tonal Control

This knob is used to either boost or cut low frequency output. When this knob is in the 12 o'clock position, there is no effect on the signal.

7. TREBLE Tonal Control

This knob is used to either boost or cut high frequency output. When this knob is in the 12 o'clock position, there is no effect on the signal.

8. MASTER Volume Control

This knob increases or decreases the volume for all channels.

9. Power On/Off

Turns the amplifier on or off.

10. LED Indicators

Signal, clip, protection, and power status LED indicators.

11. Media Player Module

Built-in media player with FM tuner, SD card slot, USB, and Bluetooth v5.2.

Front Panel Overview Cont.

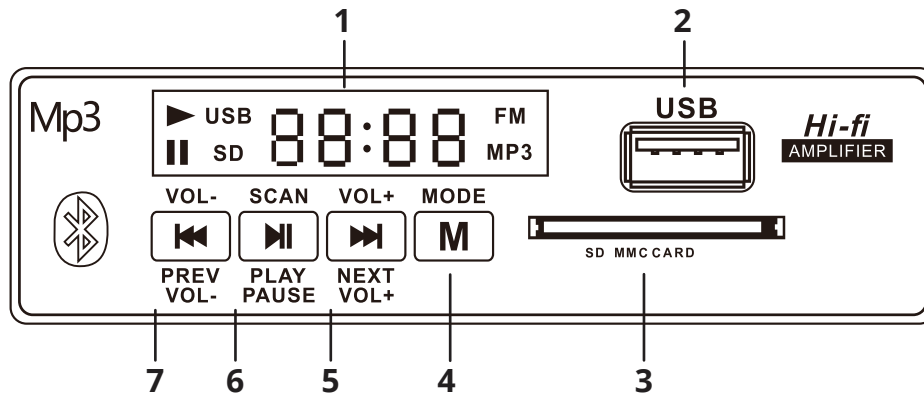

1. Display

This is the display for Mp3, FM tuner, and Bluetooth playback modes.

2. USB Input

This input allows for Mp3 playback from a portable USB drive.

3. SD Card Slot

This input allows for Mp3 playback from a SD card.

4. MODE Selector Button

This button is used to switch between FM tuner, USB, SD, and Bluetooth playback modes.

5. NEXT/VOL+ Selector Button

Use this button to step up the volume, select next FM frequency, select next Mp3 USB/SD track, select stored FM frequency from memory.

6. PLAY/PAUSE/SCAN Button

This button is used to play, pause, and scan for available FM radio stations.

7. PREV/VOL- Button

Use this button to step down volume, select previous FM frequency, select previous Mp3 USB/SD track, select stored FM frequency from memory.

Rear Panel Overview

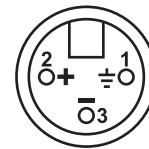
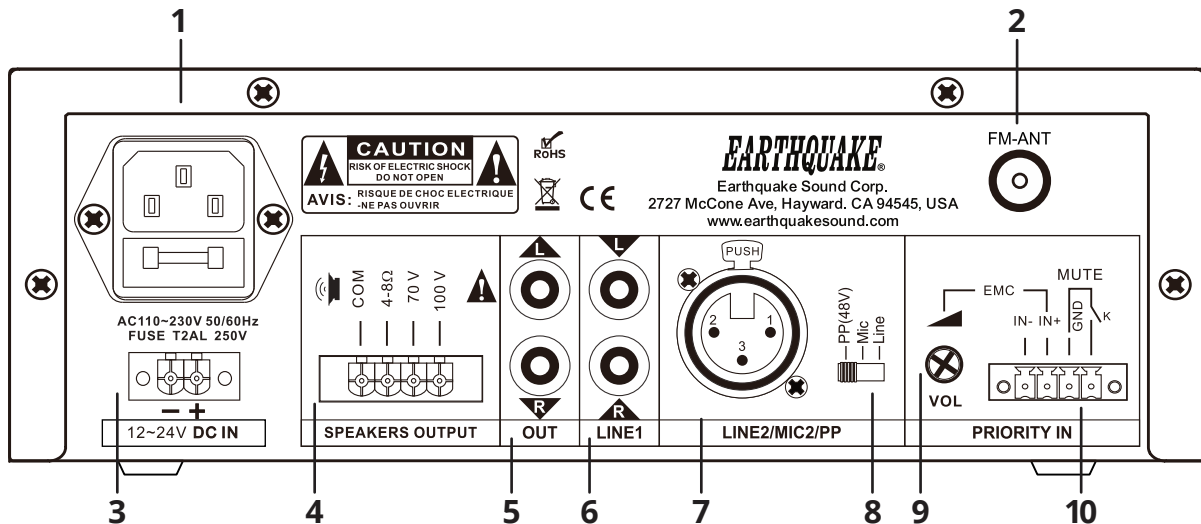

3 Pin Male XLR
 Pin1 - Ground
 Pin2 - Positive Signal
 Pin3 - Negative Signal

1. AC Power

The grounded AC power input is fused to protect the amplifier from unwanted power surges. Be sure to check the fuse rating before replacing.

2. FM Antenna

This threaded input allows for the included external FM antenna to be attached.

3. 12-24V DC Power Input

This input is used to power the amplifier from a 12~24V DC power supply.

4. Speaker Output Terminals

These terminals are used to wire speakers in a 4-8 Ohm, 70V, and 100V configurations.

5. RCA Line Output

Use this button to step up the volume, select next FM frequency, select next Mp3 USB/SD track, select stored FM frequency from memory.

6. RCA LINE1 Input

This RCA Line output is used to send signal to an additional amplifier if needed.

7. LINE2/MIC2/PP XLR Input

This input is used to receive signal from a balanced XLR connection and the use of a microphone with phantom power 48V.

8. LINE2/MIC2/PP XLR Input Selector

This selector is used to set the XLR input (item 7) to the type of output device being used.

9. EMC Level Attenuator

This attenuator is used to adjust the level of EMC.

10. Priority Inputs

These inputs are used to receive AUX signal to override or mute background music.

Notice

1. Avoid connecting 70V, 100V, or 4-8 Ohm speakers terminals simultaneously. Only choose one 70V, 100V, or 4-8 Ohm speaker connection.
2. Connect speakers that use 80% of the amplifier's rated power output only. For instance, if the amplifier has a rated output of 60 watts, connect speakers with a total power of 48 watts, such as 8 pieces of 6 watts 100V speakers.
3. Adjust the selector (rear panel item 8) before connecting the MIC2/LINE2 input for the microphone or media player input.
4. The MIC2/LINE2 can be connected to a phantom power microphone with 48V; ensure that you set the selector to PP 48V (rear panel item 8) before connecting.
5. The front panel clip LED indicator lighting up indicates that the input signal level is too high and needs to be reduced.
6. If the front panel protection LED indicator lights up, it could signal overloading, short circuit, over-heating, or poor connections. Address and resolve any issues before continuing operation.
7. The input priority hierarchy is MUTE, EMC, and other inputs (MIC1 and all other inputs).
8. The MIC1 input includes both echo and volume controls.
9. The EMC input is intended for AUX signals to override background music, with secondary priority after the MUTE input.
10. The MUTE input is for AUX signals to mute background music, with the highest priority. A closed circuit triggers MUTE, while an open circuit indicates normal amplifier operation.

Operation Guidelines

100V Line System

For 100V line systems, connect the amplifier to the first speaker in the system using a double-insulated speaker wire, which has an adequate current rating to handle the total output of the amplifier. Connect the "100V" output terminal to the positive (+) connection of the speaker and the "COM" output to the negative (-) connection of the speaker. Connect further speakers in parallel to the first speaker, with all positive and negative terminals connected, as shown below.

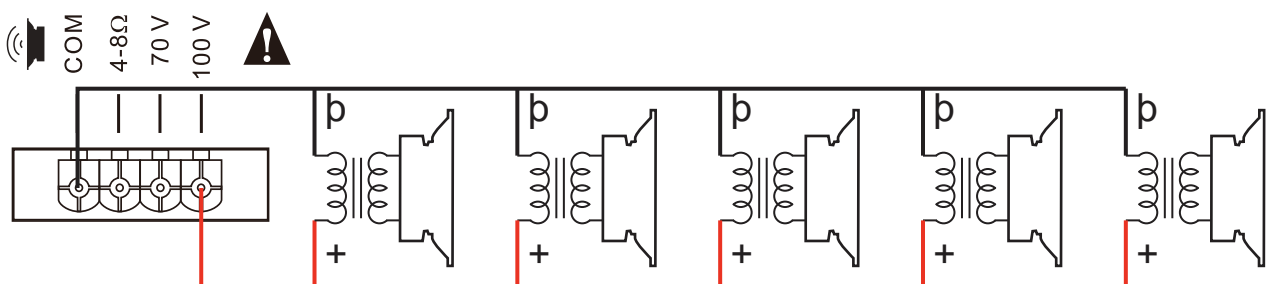

Operation Guidelines Cont.

A 100V line speaker system can comprise many speakers connected together. The power rating determines how many speakers can be used on a single amplifier. For most purposes, connecting as many speakers as needed with a combined wattage of no more than 90% of the amplifier's output power rating is advised. The terminals of a 100V speaker are connected to a transformer, and in some cases, this transformer may be "tapped" for different power ratings. These tapings can be used to adjust the wattage (and output volume) of each speaker in the system to help achieve the ideal total power of the system for the amplifier. The mixer amplifier features six speaker zone outputs; either one of six zones or a total six zone power loading shall be equivalent to or no higher than the amplifier's rated power.

Speaker Terminals

These terminals provide 3 low voltage outputs: 4, 8, and 16, depending on your speaker combination. A 70V/100V commercial output is also available. Please note that one wire only should be connected to the COM screw and one wire to the selected impedance or voltage. Multiple combinations cannot be done at the output level. Four different types of connections are provided. The low impedance section: 4–8 Ohm is designed for a small amount of speakers to be connected to your amplifier. The 70V/100V section is specially designed for a multiple speaker distribution. When using the 70V/100V output, speakers must be equipped with a 70V/100V transformer. The maximum number of speakers to be placed on your distribution line is related to the power allocated to each speaker. The total wattage set on the secondary side of the transformers on your speaker line must not exceed the maximum RMS output power of 60W. Failure to respect this may cause permanent damage to the amplifier.

Operation Steps

- After connecting all the cables to the amplifier, ensure that all rotary controls are turned down before switching the power on. An "ON" LED indicator will light up once powered on. Set the BASS and TREBLE controls to the 12 o'clock position (pointing straight up) and adjust the MASTER rotary control to a moderate level for testing.
- Ensure a signal is being fed to a LINE input and slowly raise the volume control for that channel until the sound is audible through the speakers. Adjust the MASTER to the appropriate volume level and lower the channel volume control if needed.
- Please test the system initially with the integrated USB/SD media player or FM tuner. The signal LED on the amplifier displays its output, while the clipping (CLIP) or protection (PRO) LED should only briefly illuminate while in operation. If the CLIP and PRO LEDs remain on for more than a quick flash, it might signal signal distortion or clipping in the output signal, prompting you to lower the MASTER volume.
- If you have a microphone connected to the MIC1 input, turn it on. If phantom power is needed (MIC2 only), activate this feature using the PP 48V selector (rear panel item 8). Adjust the volume control slowly while speaking into the microphone until the desired volume level is achieved. Avoid having the microphone pick up sounds from the speakers to prevent feedback such as squealing or howling noises.
- When the VOX feature is activated, audio playback on other channels automatically decreases in volume when speaking into MIC1. The attenuator is utilized to adjust the mute level up or down.
- Apart from the channel and MASTER volume controls, the front panel includes BASS and TREBLE controls that alter the amplifier's overall output tone. At the 12 o'clock position, these controls do not impact the signal (neither boost nor cut). Rotating the BASS control clockwise or counterclockwise from the 12 o'clock position will either boost or cut low frequencies. Similarly, rotating the TREBLE control clockwise or counterclockwise from the 12 o'clock position will either boost or cut high frequencies.
- Fine-tune echo effect by adjusting the ECHO VOL control (front panel item 3) to increase or decrease the volume.

Operation Guidelines Cont.

Media Player

The MXA-100BT mixer amplifier incorporates a media player within the front panel, allowing audio playback through an FM tuner with a provided antenna, MP3 files from a USB or SD card, and wireless streaming from Bluetooth-compatible devices. To switch between MP3/FM/Bluetooth modes, simply press the Mode button as indicated on the front panel LED display. Additionally, the included IR remote enables remote control of the media player functions within a range of 10 to 30 meters.

Operation Steps

- After connecting all the cables to the amplifier, ensure that all rotary controls are turned down before switching the power on. An "ON" LED indicator will light up once powered on. Set the BASS and TREBLE controls to the 12 o'clock position (pointing straight up) and adjust the MASTER rotary control to a moderate level for testing.
- Ensure a signal is being fed to a LINE input and slowly raise the volume control for that channel until the sound is audible through the speakers. Adjust the MASTER to the appropriate volume level and lower the channel volume control if needed.
- Please test the system initially with the integrated USB/SD media player or FM tuner. The signal LED on the amplifier displays its output, while the clipping (CLIP) or protection (PRO) LED should only briefly illuminate while in operation. If the CLIP and PRO LEDs remain on for more than a quick flash, it might signal distortion or clipping in the output signal, prompting you to lower the MASTER volume.
- If you have a microphone connected to the MIC1 input, turn it on. If phantom power is needed (MIC2 only), activate this feature using the PP 48V selector (rear panel item 8). Adjust the volume control slowly while speaking into the microphone until the desired volume level is achieved. Avoid having the microphone pick up sounds from the speakers to prevent feedback such as squealing or howling noises.
- When the VOX feature is activated, audio playback on other channels automatically decreases in volume when speaking into MIC1. The attenuator is utilized to adjust the mute level up or down.
- Apart from the channel and MASTER volume controls, the front panel includes BASS and TREBLE controls that alter the amplifier's overall output tone. At the 12 o'clock position, these controls do not impact the signal (neither boost nor cut). Rotating the BASS control clockwise or counterclockwise from the 12 o'clock position will either boost or cut low frequencies. Similarly, rotating the TREBLE control clockwise or counterclockwise from the 12 o'clock position will either boost or cut high frequencies.
- Fine-tune echo effect by adjusting the ECHO VOL control (front panel item 3) to increase or decrease the volume.

Bluetooth Operation

- To wirelessly stream audio to the MXA-100BT using Bluetooth, you must pair a Bluetooth-enabled device like a smartphone or tablet with the amplifier's built-in Bluetooth receiver while being in close proximity.
- To pair a device with the MXA-100BT amplifier, access the Bluetooth settings on the source device, search for available devices, and choose BT66078 from the list. Once paired, the display on the amplifier will indicate a successful connection. Use "1234" as the password if required.
- Set the source device to connect as an audio device and play music on the smartphone or tablet. The audio will play in the designated zone.
- Adjust the volume of the audio player by using the PREV/VOL- and NEXT/VOL+ buttons. Press and hold these buttons to decrease or increase the volume.
- If the source device moves out of range or changes modes, the connection will be lost. Re-entering Bluetooth mode or moving back into range will re-establish the connection. You may need to re-select the audio connection on the source device.

Operation Guidelines Cont.

USB/SD Card Playback

Push a USB drive into the USB port or an SD card into the SD input. Press the Mode button to ensure that the player is set to play from the required portable storage device. Press the PLAY/PAUSE button to play the current track and press again to pause as needed. Press the PREV/VOL- and NEXT/VOL+ buttons to select the next or previous track or press and hold to adjust the volume as needed.

FM Tuner Operation

Press the MODE button to switch to the FM tuner function. Use the PREV/VOL- and NEXT/VOL+ buttons to select a stored channel or press and hold them to adjust the volume. The SCAN/PLAY/PAUSE button is used for starting and stopping a scan as well as clearing the memory. The included remote will give the user more functionality than the front panel.

Tuning and Storing Stations

Auto Scanning

Press the SCAN/PLAY/PAUSE button on the front panel or remote to start auto scanning for available stations to store into memory. Auto scanning can be stopped at any time by pressing the SCAN/PLAY/PAUSE button. You may also double press this button to clear the memory.

Upon finding a station, the auto scan will pause for a moment and flash "P" followed by a number indicating that the station has been programmed into memory. When the auto scan is completed, you may use the PREV/VOL- and NEXT/VOL+ buttons to select through stored stations from memory.

Manual Programming

When auto scanning is not necessary, you may set up a custom selection of stations manually. To do this, it is first recommended to clear out the memory if there are already stored stations. Double-click the SCAN/PLAY/PAUSE button to ensure that the memory has been cleared. You will then need to input a station just before the desired one using the remote and then press and hold the NEXT/VOL+ button to seek to the station. Once the station is found, it will pause for a moment and flash "P" followed by a number (P01) indicating that the station has been programmed into memory. More stations may be added by doing the exact procedure. Remember that double-clicking the SCAN/PLAY/PAUSE button on the front panel or remote will clear the memory and you will have to start over again.

Example

If the desired station is 105.3 that you want to store into memory, then input a station before it such as 105.1. When 105.1 is displayed on the front panel, press and hold the NEXT/VOL+ button and the tuner will seek ahead to the next available station and add it to memory.

Connections

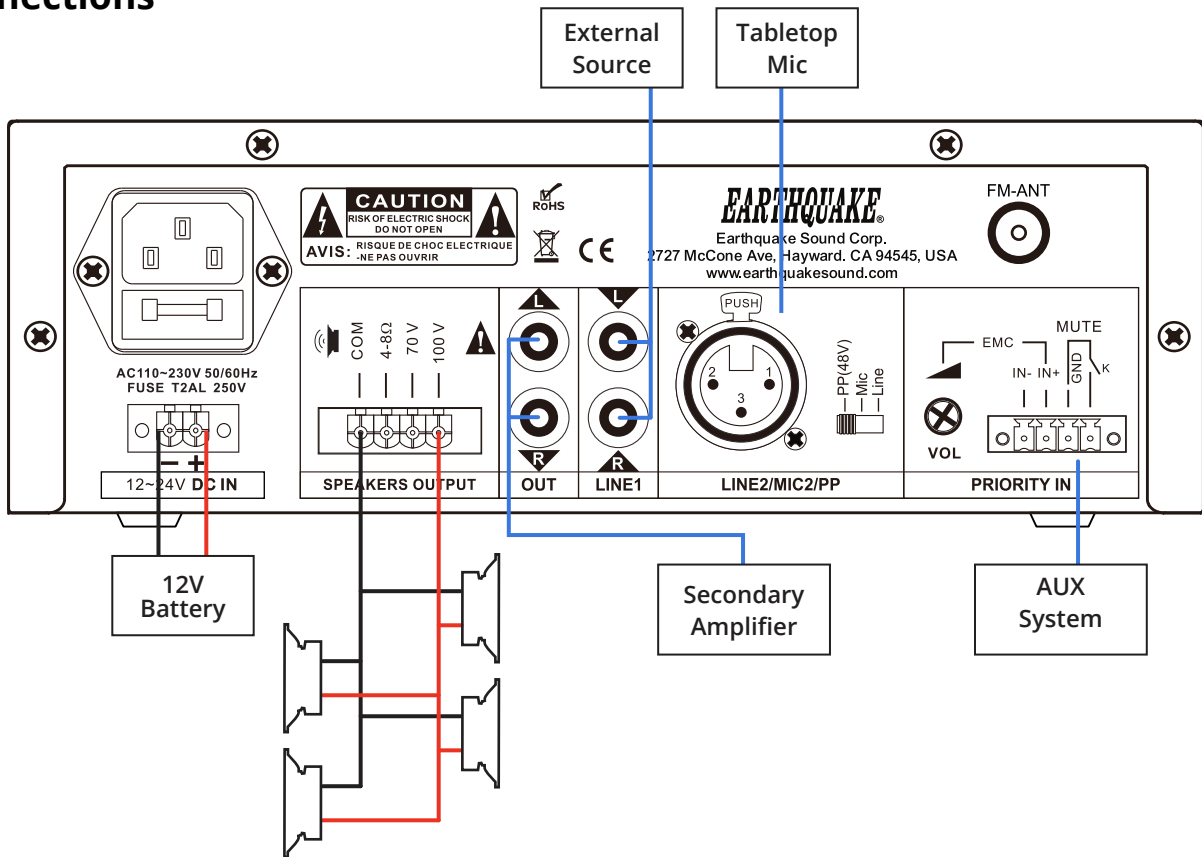

70V Configuration - PCS6.5 Pendant Speaker

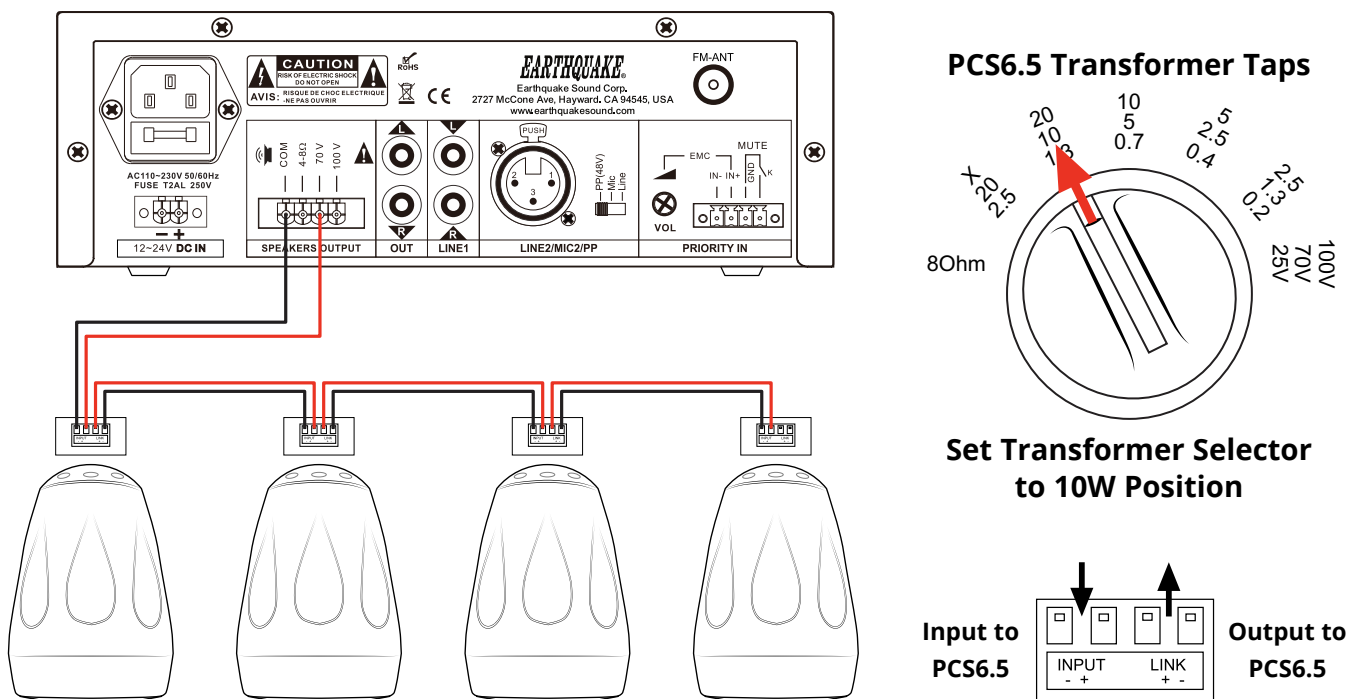

70V Configuration With Subwoofer - High Level

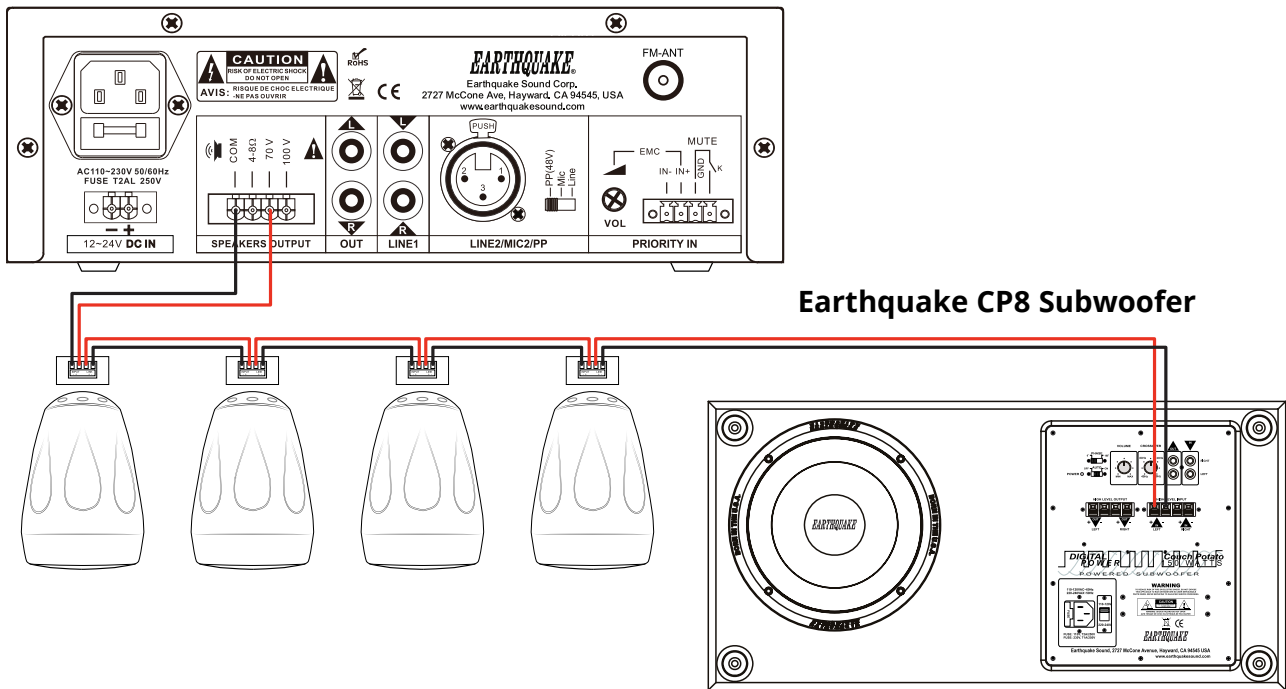

Use Link Output From PCS6.5 to Connect Subwoofer to High Level Inputs

70V Configuration With Subwoofer - High to Low Level

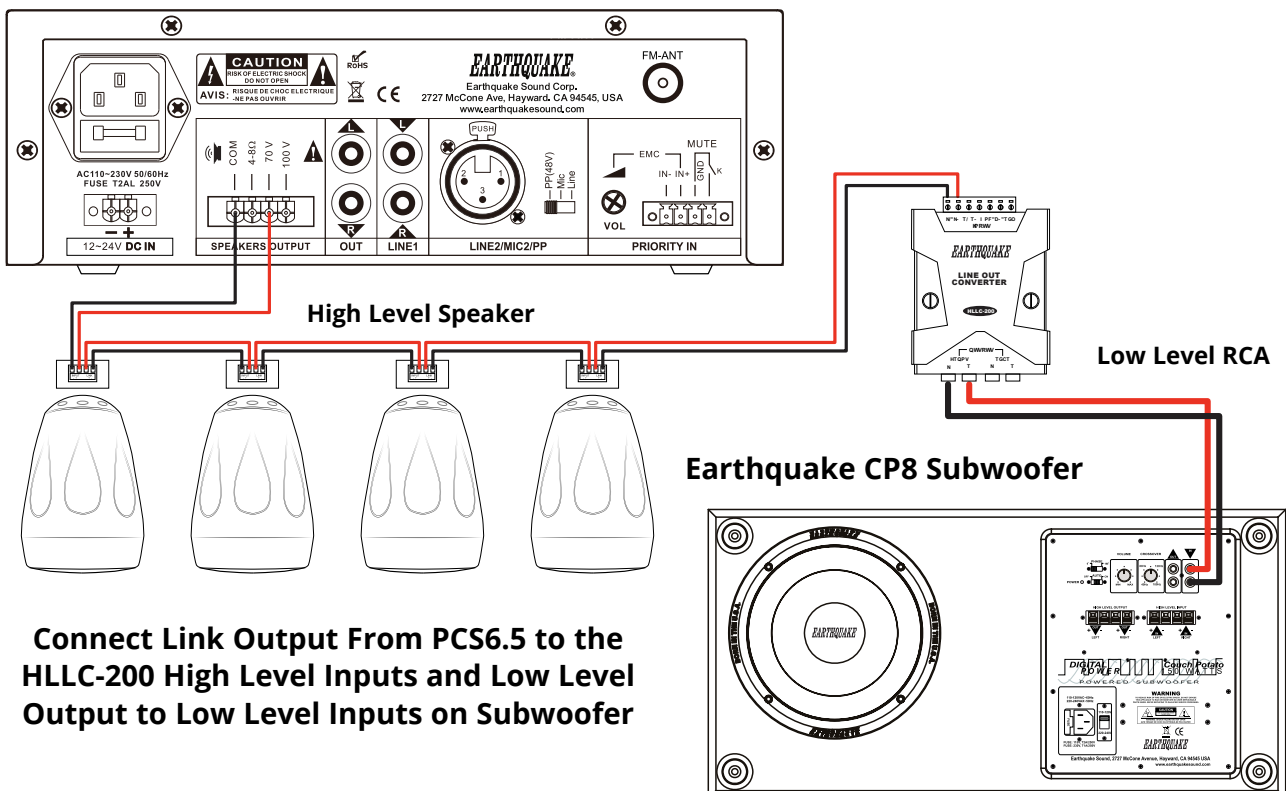

Connect Link Output From PCS6.5 to the HLLC-200 High Level Inputs and Low Level Output to Low Level Inputs on Subwoofer

Specifications

| | |
|---------------------------|---|
| Power Output | 1 x 60W RMS, 1 x 200W MAX |
| Speaker Outputs | 4–8 Ohm, 70V, 100V |
| Inputs | 1/4-inch MIC1, XLR MIC2/LINE2/PP +48V, LINE1 RCA, Priority In |
| Outputs | LINE RCA, Speaker level |
| Bluetooth Version | v5.2 |
| Input | Mic: 5-8mV, 600Ω, Line: 150-470mV, 10kΩ, unbalanced RCA |
| Line Out | 0.775 (0dBV) |
| Frequency Response | 60Hz-15kHz (±3dB) |
| S/N Ratio | Line ≥ 85dB, Mic ≥ 72dB |
| THD | < 0.5% |
| Protection | Short, clip, overload, and thermal |
| Power Consumption | 80W |
| Power Supply | 110~230V AC 50/60Hz, 12V DC |
| Fuse Rating | T2AL 250V |
| Overall Dimensions | 8.66 in. x 9.44 in. x 2.95 in., 220mm × 240mm × 75mm |
| Weight | 5.73 lb / 2.6 kg |

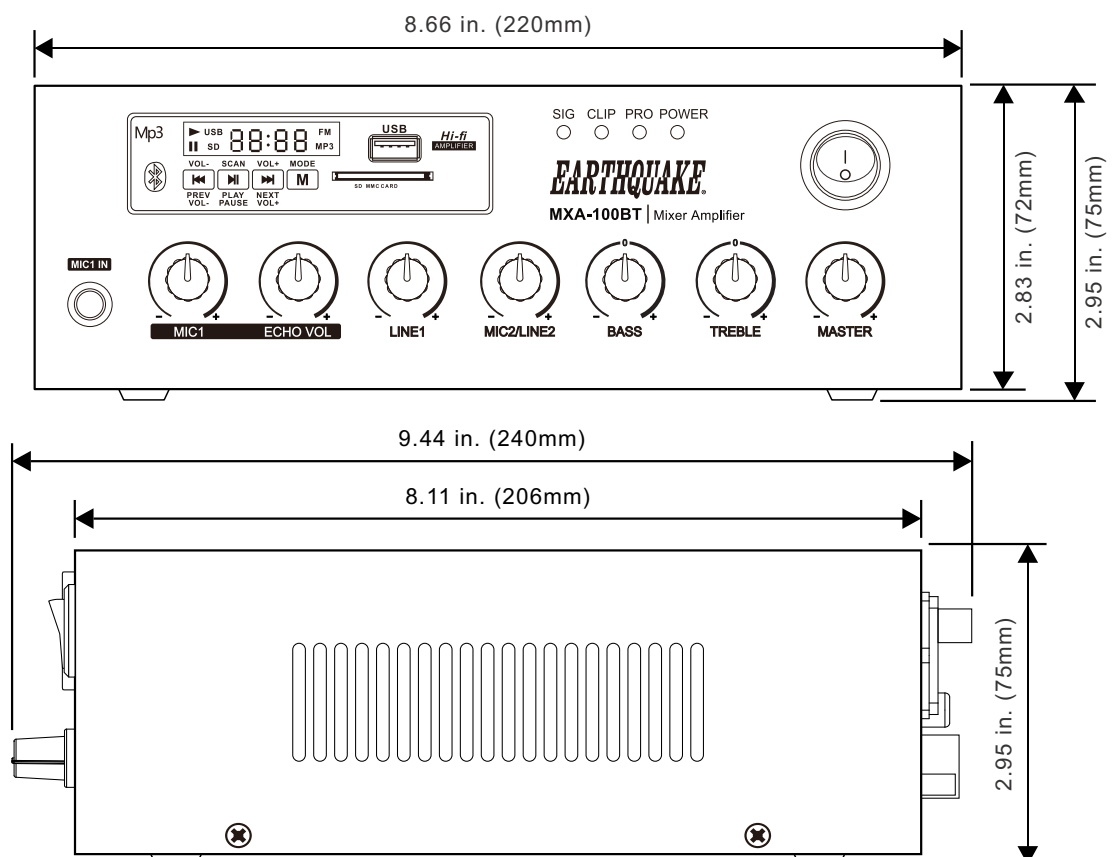

Troubleshooting

| | |
|---|--|
| <p>No power LED on front panel</p> | <ul style="list-style-type: none"> • Ensure IEC lead is in good condition and connected properly. • Check battery condition If 12V DC power input is being used. • Remove the fuse from the holder and check its condition. • Ensure that the power switch is on. |
| <p>Power LED is on but no other LEDs and no output</p> | <ul style="list-style-type: none"> • Check input signal and condition of the input connection leads. • Check the MASTER, MIC, LINE, or MEDIA controls are turned up. |
| <p>Power and output LEDs are On but no output</p> | <ul style="list-style-type: none"> • Check that the speaker output terminals are connected correctly. • Ensure speakers are working and test on another amp if needed. |
| <p>Bluetooth cannot connect</p> | <ul style="list-style-type: none"> • Ensure that Bluetooth is enabled for the transmitting device. • Ensure that the transmitting device is within range of the amplifier. • Check that Bluetooth is displayed on the front panel. • IF there are more than one Bluetooth devices, check each in turn. |
| <p>No audio from connected Bluetooth device</p> | <ul style="list-style-type: none"> • Ensure volume controls are not turned down on transmitting device. • Check volume and Play/Pause button in case Bluetooth is muted. |
| <p>USB player will not play audio from media</p> | <ul style="list-style-type: none"> • Press PLAY on transport controls. • Check USB device is connected properly (remove and re-insert). • Check file types – standard compressed audio files required. • Check USB device works on a PC or Mac for standard playback. |
| <p>Output is very loud or distorted</p> | <ul style="list-style-type: none"> • Check level of input signal is not too high. • Reduce MIC, LINE IN, MEDIA and/or MASTER level. • Ensure Hi-Z line level input(s) not connected via MIC input. |
| <p>Output is working but at low level</p> | <ul style="list-style-type: none"> • Check that the input audio source level is not too low. • Increase MIC, LINE IN, MEDIA and/or MASTER level. • Check for quiet recording of media files on USB. |
| <p>Feedback from microphone</p> | <ul style="list-style-type: none"> • Face microphone away from speakers and monitors. • Turn down MIC and/or MASTER level. |
| <p>Amplifier overheating</p> | <ul style="list-style-type: none"> • Ensure cooling vents are clear from debris and dust. • Check that 8 speakers are not connected to 100V terminals. • Ensure total 100V speaker wattage is lower than amplifier rating. • Ensure that 100V and 8 speakers are not both connected. • Ensure that total load connected to 8 output is not less than 8. |

Five (5) Year Limited Warranty

Earthquake warrants the original purchaser that all Factory Sealed New Audio Products to be free from defects in material and workmanship under normal and proper use for a period of five (5) years from the date of purchase (as shown on the original sales receipt with serial number attached/written on it). The five (5) year warranty period is valid only if an authorized Earthquake dealer properly installs the product and the warranty registration card is properly filled out and sent to Earthquake Sound Corporation. If a non-authorized party installs the product, a ninety (90) day warranty period will be applied.

(A) Five (5) years limited warranty plan coverage guidelines:

- **First year:** Earthquake pays for labor, parts, and ground freight (only in US mainland, not including Alaska and Hawaii) (shipping to us is not covered).
- **Second, third, fourth & fifth year:** Earthquake pays labor only. Customer pays for parts and freight both ways.

(B) Warning:

Products (sent for repair) that are tested by Earthquake technicians and deemed to have no problem(s) will not be covered by the five (5) year limited warranty. Customer will be charged a minimum of one (1) hour of labor (at the ongoing rates) plus shipping charges back to customer.

Each product sent for repair must be packaged in its original packaging. Otherwise, there will be repackaging charge in addition to labor, parts and shipping charges.

(C) Earthquake will repair or replace - at our option - all defective products/parts subject to the following provisions:

- Defective products or parts have not been modified or repaired by anyone other than a technician approved by the Earthquake factory.
- Products/parts are not subjected to negligence, misuse, improper use or accident, damaged by improper line voltage, used with incompatible products or have its serial number or any part of it altered, defaced or removed, or have been used in any way that is contrary to Earthquake's written instructions.

(D) Warranty Limitations:

Warranty does not cover products that have been modified or abused, including but not limited to the following:

- Damages to cabinet/casing finish due to misuse, abuse or improper use of cleaning materials/methods.
- Fading and or deterioration of speaker components & finish due to improper exposure to elements.
- Bent amplifier casing, damaged finish on the casing due to abuse, misuse or improper use of cleaning material.
- Burnt tracers on PCB.
- Product/part damaged due to poor packaging or abusive shipping conditions.
- Subsequent damage to other products.

A warranty claim will not be valid if the warranty registration card is not properly filled & returned to Earthquake with a copy of the sales invoice.

Five (5) Year Limited Warranty Cont.

(E) Service Request:

To receive product service, contact Earthquake service department at (510) 732-1000 and request an RMA number (Return Material Authorization). Items shipped without a valid RMA number will be refused. Make sure you provide us with your complete/correct shipping address, a valid phone number, and a brief description of the problem you are experiencing with the product. In most cases, our technicians might be able to resolve the problem over the phone; thus, eliminating the need to ship the product.

(F) Shipping Instructions:

Product(s) must be packaged in its original protective box(es) to minimize transport damage. Shipper claims regarding items damaged in transit must be presented to carrier. Earthquake Sound Corporation reserves the right to refuse improperly packed product. Original sales receipt must accompany product returned for service. We encourage you to include with the package a written description of the problem.

Ship product to: Earthquake Sound Corp. 2727 McCone Avenue, Hayward, CA 94545. Phone: (510) 732-1000. You are responsible for the cost of shipping the product to Earthquake Sound Corporation.

(G) Disputes Resolution:

All disputes - between clients and Earthquake Sound Corporation - resulting from the five (5) years limited warranty policy must be resolved according to the laws & regulations of the county of Alameda, California.

For Your Records

Date of Purchase: _____

Authorized Dealer/Installer Info:

Name: _____

Address: _____

Phone: _____

Serial Number:

Notes



The Sound That Will *Move* You

Earthquake Sound reserves the right to amend details of the specifications without notice.

© Copyright Earthquake Sound Corporation

Earthquake Sound Corporation

2727 McCone Avenue, Hayward CA, 94545

Phone: (510) 732-1000 U.S. Toll Free: (800) 579-7944 Fax: (510) 732-1095