



KOMPRESSOR

User's Manual



Table Of Contents

Introduction.....	3
Important Safety Instructions.....	4
Installation and Operation.....	5
Warranty Information.....	6-7



Earthquake Sound Corporation
2727 McCone Avenue
Hayward, CA 94545
Tel: 510-732-1000
Fax: 510-732-1095

Customer Technical Support
US Toll Free: 1-800-576-7944
tech@earthquakesound.com

This document should not be construed as a commitment on the part of Earthquake Sound Corporation. The information is subject to change without notice. Earthquake Sound Corporation assumes no responsibility for errors that may appear within this document.

© 2017 Earthquake Sound Corporation. All rights reserved.

INTRODUCTION:

Thanks for purchasing Earthquake Sound's K10.

Getting tired of the "just me" type of subwoofer tube, Joseph Sahyoun (President of Earthquake Sound Corporation) integrated the patented SLAPS (Symmetrically Loaded Passive System) into the smallest most compact tube; thus creating the "KOMPRESSOR". The latest and most advanced bass cylinder to ever exist.

The patented SLAPS allows the subwoofer tube to be tuned to ridiculously low frequencies, while getting massive amount of SPL in the sub-harmonic range. The KOMPRESSOR is technologically the most advanced tube available on the market today. The small package addresses looks and performance: the drivers move over 3 inches, clearly beyond the norms of any other drivers. The KOMPRESSOR is guaranteed to shake loose the trunk of your car and its contents.

Here at Earthquake, we believe that good bass does not have to be expensive, it does not have to eat up your trunk space either. Earthquake engineers wrote the book on deep bass extension. First, they molded tube enclosures from high density material; next they developed new drivers optimized specifically for use in these tubes... Hence, the "K" subwoofer tube: the easiest and the most economical way to add deep, clean, all around bass to your existing car audio system.

The tube construction is rugged, with durable moldings designed to blend with any car interior. All hardware needed to securely mount the tube is included in the package. The "K" subwoofer tubes are passive tuned with the "SLAPS" for optimum bass response and long lasting performance. The drivers feature 4-wound flat wire voice coils (2 inch diameter) for deeper low frequency response and smooth high frequency roll off; thus eliminating the need for external crossover. The Long Throw piston assembly provides excellent sub-harmonic extension.

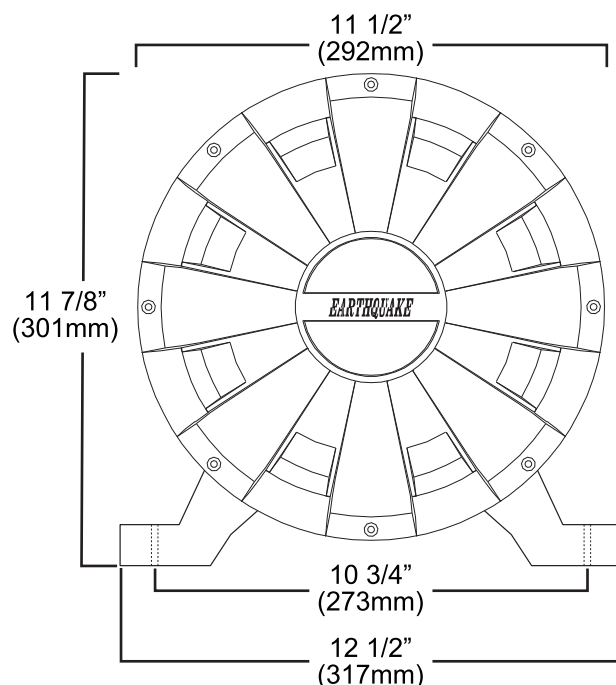
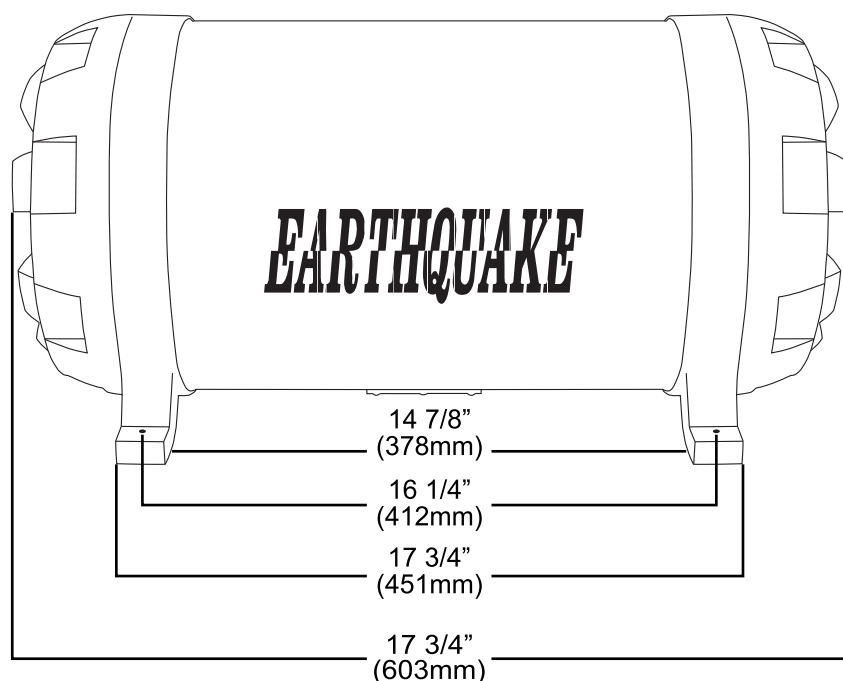

IMPORTANT SAFETY INSTRUCTION - READ FIRST

Before you begin:

- 1) Locate an area in the rear of the vehicle where you would like to install your tube subwoofer.
- 2) Orient the subwoofer so that the active driver-front of the tube- fires into a corner, about 2 to 4 inches away.
- 3) Inspect the mounting area to ensure that the mounting screws will not damage the gas tank, electrical wiring, fuel lines, spare tire, or any other parts of the vehicle.
- 4) Ensure that the chosen surface is solid enough to withstand the stress of subwoofer mounting.

In a hatchback: the tube should lay parallel to the rear of the vehicle, firing into the corners.

In a sedan: the tube should be secured against the sides of the trunk, firing toward the rear of the vehicle.

In a trunk: the tube should be mounted behind seat, firing outward.

RULE OF THUMB: Position the tube so the active driver is facing a hard reflective surface (3-5 inches away). This adds a 3dB gain to the total system response.

Mounting instructions:

- 1) Place the tube subwoofer in the desired mounting location and mark the correct place on your vehicle to drill the required mounting holes.
- 2) Mount the tube subwoofer by screwing or bolting to the vehicle through both holes in each leg. Be sure that your tube subwoofer is securely fastened to your vehicle!

Note: Due to the shifting and jarring that will occur in a vehicle, the mounting legs should be checked periodically to ensure that they are fastened securely in place.

INSTALLATION AND OPERATION

Wiring instructions:

Locate the terminal cup on the rear of the tube subwoofer. Insert the positive speaker output lead from your amplifier into the gold plated red terminal on your subwoofer tube. Repeat the process with the negative amplifier lead and black terminal.

Wiring multiple tubes:

Care should be taken to wire all speakers in proper relative phase. However, if your bass response does not increase after wiring an additional tube, you must reverse its polarity. To accomplish this, turn off your system, then reverse the leads on the second tube subwoofer. If the bass response improves, your phasing is correct.

WARRANTY INFORMATION:

Limited Warranty (USA only)

Earthquake Sound warrants to the original purchaser that all factory Sealed New Audio Products to be free from defects in material and workmanship under normal and proper use for a period of one (1) year from the date of purchase (as shown on the original sales receipt with serial number affixed/ written on it.) The one (1) year warranty period is valid only if an authorized Earthquake dealer properly installs the product and the warranty registration card is properly filled out and sent to Earthquake Sound Corporation. If a non-authorized party installs the product, a ninety (90) day warranty period will be applied.

A) One (1) year limited warranty plan coverage guidelines:

Earthquake pays for labor, parts, and ground freight (only in US mainland, not including Alaska and Hawaii. Shipping to us is not covered).

(B) Warning:

Products (sent for repair) that are tested by Earthquake technicians and deemed to have no problem(s) will not be covered by the one (1) year limited warranty. Customer will be charged a minimum of one (1) hour of labor (at the ongoing rates) plus shipping charges back to customer.

(C) Earthquake will repair or replace at our option all defective products/parts subject to the following provisions:

- Defective products/parts have not been altered or repaired by other than an Earthquake factory-approved technicians.
- Products/parts are not subjected to negligence, misuse, improper use or accident, damaged by improper line voltage, used with incompatible products or have its serial number or any part of it altered, defaced or removed, or have been used in any way that is contrary to Earthquake's written instructions.

(D) Warranty Limitations:

Warranty does not cover products that have been modified or abused, including but not limited to the following:

- Damages to cabinet/casing finish due to misuse, abuse or improper use of cleaning materials/methods.
- Fading and or deterioration of speaker components & finish due to improper exposure to elements.
- Bent amplifier casing, damaged finish on the casing due to abuse, misuse or improper use of cleaning material.
- Burnt tracers on PCB.
- Product/part damaged due to poor packaging or abusive shipping conditions.
- Subsequent damage to other products

A warranty claim will not be valid if the warranty registration card is not properly filled & returned to Earthquake with a copy of the sales receipt.

(E) Service Request:

To receive product service, contact Earthquake Service Department at (510) 732-1000 and request an RMA number (Return Material Authorization). Items shipped without a valid RMA number will be refused. Make sure you provide us with your complete/correct shipping address, a valid phone number, and a brief description of the problem you are experiencing with the product. In most cases, our technicians might be able to resolve the problem over the phone, thus eliminating the need to ship the product.

(F) Shipping Instructions:

Product(s) must be packaged in its original protective box(es) to minimize transport damage and prevent repackaging cost (at the ongoing rates). Shipper claims regarding items damaged in transit must be presented to carrier. Earthquake Sound Corporation reserves the right to refuse improperly packed product. A copy of the original sales receipt must accompany product returned to service. We encourage you to include with the package a written description of the problem. Ship product to:

Earthquake Sound Corp.
2727 McCone Avenue, Hayward, CA 94545.
Tel: (510) 732-1000.

You are responsible for the cost of shipping the product to Earthquake Sound Corporation.

(G) Disputes Resolution:

All disputes between clients and Earthquake Sound Corporation resulting from the one (1) year limited warranty policy must be resolved according to the laws & registration of the county of Alameda California.

Product Registration

This K-10 can be registered by returning the Product Registration card attached to this manual. Please also retain the sales receipt which represents proof of purchase and helps expedite warranty issues.



Earthquake Sound reserves the right to amend details of the specifications without notice.

© Copyright Earthquake Sound Corporation
Earthquake Sound Corporation
2727 McCone Avenue, Hayward CA, 94545
Phone: (510) 732-1000 U.S. Toll Free: (800) 579-7944 Fax: (510) 732-1095